

*"Interior Solutions.....from Concept to Creation"*

# PRE-QUALIFICATION

---

Golden Link Group of Companies

Dubai

Abu Dhabi

Ras Al Khaimah

## Key notes

### **GOLDEN LINK**

Group of companies and Golden Link contg & Décor LLC established in Dubai early 2003 with diversified activities in construction , interior fit out lighting electro mechanical glass aluminum and joinery industry

Today we serve diversified field from hospitality , restaurants , residential, commercial, public buildings, and govt sectors with turnkey projects varying from construction, interior fittout, furniture, and mep services etc.

The employee head count stays at 200 plus including architects , engineers, designers, technicians involving all skilled and non skilled staff in their respective fields.

The projects are undertaken all over UAE, GCC and South east Asia including African region.

Our in-house production capabilities with appropriate HSC policy and quality control is always leads us the way ahead from our so called competitors. Delivery of customized or tailored solutions for any interior projects is accommodated in turn key contracts, or even execution only or design and project management.

Having association with procurement and project management cogenerates from far east and EU we source out best solutions for hospitality in terms of FF & E contracts.



*"Interior Solutions.....from  
Concept to Creation"*

## **INDEX**

- ***Abstract***
- ***Introduction***
- ***Projects & Gallery***
- ***Submittals & Drawings***
- ***Green Building, FSC Certificates***

**GOLDEN** *link*  
CONTRACTING & DECORATION L L C  
INTERIOR DESIGN | SUPERVISION | CONTRACTING



*"Interior Solutions.....from  
Concept to Creation"*

# **ABSTRACT**





# Golden Link Group

## **ABSTRACT**

### GROUP COMPANIES & ACTIVITIES

- 1) Golden Link Contracting & Decoration LLC  
**(Interior Fit-out, Contracting & Supervision)**
- 2) Golden Link Industries LLC  
**(Wooden Joinery / Wooden Doors / Kitchen Cabinets / Wardrobes etc.)**
- 3) Golden Lux General Trading FZC  
**(Professional LED Lighting)**
- 4) Super Golden Link Technical Works LLC  
**(MEP & Technical Services)**

### INFRASTRUCTURE

#### OFFICES

- Operations Office : Warehouse # 5,  
Sana Street, Ras Al Khor Industrial Area # 1  
Dubai
- Factory / Showroom Office : Plot # 89A, Jazeera  
RAKIA Industrial Zone  
Ras Al Khaimah, UAE
- Ajman Office : SM-Office, 11-257 D  
Ajman Free Zone  
Ajman
- Contact Details : Phone : 04 388 5425  
Fax : 04 388 5426  
Email : [goldnlnk@eim.ae](mailto:goldnlnk@eim.ae)  
Website : [www.golden-link.com](http://www.golden-link.com)
- Joinery Factory : A well equipped joinery factory of 14,000 Sqft  
to support all wood works with real craftsmen



Celebrating 15 years

## **FLEETS**

Isuzu Pick up (3 Ton)	::	2	Nos
Canter Pick up (3 Ton)	::	2	Nos
Nissan Urvan - Van	::	6	Nos
Isuzu Pick up (Small)	::	2	Nos
Mini Bus (Mitsubishi)	::	2	Nos
Bus (Tata)	::	1	Nos
Forklift	::	1	Nos
Great Wall Pick up	::	2	Nos
Cars	::	18	Nos

## **THE CREW**

Managerial	::	19
Operational	::	71
Associated Companies'	::	137

## **Performance Data Base on Utility / Form / Functioning**

Sn	Type of Work	Unit	2015	2016	2017	Total	Value (Aed)
1.00	Joinery / Carpentry	Sqm	8900	10750	57519	77169	<b>140,833,750.00</b>
2.00	Showrooms / Offices	Sqm	2050	1800	11295	15145	<b>45,662,850.00</b>
3.00	Hotels / Hospitality	Sqm	150	8600	7647	16397	<b>65,178,750.00</b>
<b>Total:-</b>							<b>251,675,350.00</b>

## **Authorities of Approvals Involved**

- a) Dubai Municipality (DM)
- b) Dubai Civil Defence (DCD)
- c) Dubai Electricity & Water Authority (DEWA)
- d) Concordia
- e) Tecom
- f) Emmar
- g) Trakhees

## **Management & Quality System**

In order to be more efficient & professional, we have initiated procedures for obtaining **SO 9001 certification**.

**GOLDEN** *link*  
CONTRACTING & DECORATION L L C  
INTERIOR DESIGN | SUPERVISION | CONTRACTING



*"Interior Solutions.....from  
Concept to Creation"*

# **INTRODUCTION**

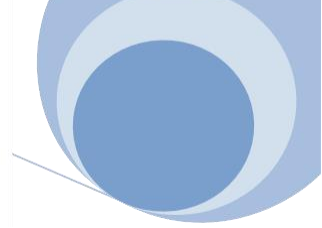

## INTRODUCTION

**Golden Link** group of companies are spread over the Middle East, with various business units. The company was formed in 2002 with the intention of bringing high quality original interior design to the residential and commercial market places. The company now has a large portfolio of completed projects ranging from single room renovations, through whole dwelling refurbishments up to interactional commercial projects.

We provide the finest solutions to corporate, financial organizations, hotels, hospitals, offices, schools, labour camps, villas and retail outlets for the requirement of professional advanced **Interior Designing**, turnkey commercial projects, conceptual designing, space planning, project presentation customized furniture, mechanized joining, PVC ceramic flooring, wall tiling, insulation, warehouse storage, false ceiling, partitions, decorative paintings, surface finishes, gypsum works, curtains, venetian, vertical blinds, mechanical, electrical, plumbing, air conditioning, LPG installation, outdoor, indoor sign, pop-up roll up banners, large format banners, vinyl graphics, posters, bill boards, 3D carving and engraving. **GOLDEN LINK** has been consistently growing now having successfully enhanced business efficiency for thousands of multinational organizations, corporate and villas all over the UAE.

**GOLDEN LINK** is a totally integrated interior solution provider and is a vision of young talented and experienced group of professionals and entrepreneurs, committed to provide services of high quality and reliable solution to all its clients. **GOLDEN LINK** strives to remain as a benchmark by which the industry measures quality services.

The most valued asset within our company is our work forces, who are technically qualified professionals and engineers with multi man – years of experience on our suit of solutions. The team is committed and capable of providing innovative and reliable solutions to challenging business requirements. It has always been our effort to offer services with optimum quality in ideal solutions tailored to fit the actual interior requirements and needs of individuals and companies from various business verticals. Known for our wide range of comprehensive versatile applications. We develop

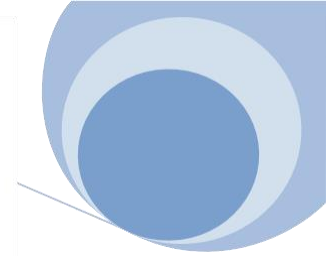

Interior solution that help companies to grow and steer ahead with aesthetic up keep minimizing lose and maintenance. Based on our far reaching experience we have been providing the right answers to highly growing and interior business questions for nearly 12 years all with great success. In short we are a company that helps individuals and organizations to meet their specified interior furnishing requirements up to international standards with minimum time cost, that automate business process that invariably increase productivity and efficiency.

## What makes us unique ?

Based on the fact that complex business problems require innovative solutions, we at **GOLDEN LINK** take a different approach to our projects. In keeping with our esteemed client's overall vision and strategies, our highly trained team of experts, which include exceptional technical professionals, vertical specified functional consultants and engineering consultants help companies prepare for the future interiors designing need for categorized purpose. To that end the interior furnishing solutions we provide are designed specifically for the client's specific requirements.

## Develop profit margins

To our way of thinking the aesthetic environment and professional interior designing is an unavoidable fact that leads to personal improvement, sustainability and international quality standards for a growing organization. At the same time is also important to ensure efficiency of the work force, capacity of the Manufacturing technology, quality of the products, and reliability of the services. We at **GOLDEN LINK** have proven to help thousands of residents and organizations to meet their complete interior furnishing needs up to their satisfaction, improving efficiency and creating a better environment. This way we have helped our esteemed clients to decrease heavy loss due to substandard interior furnishing. By applying the latest interior solutions we help set our client's for ahead of their competitors.

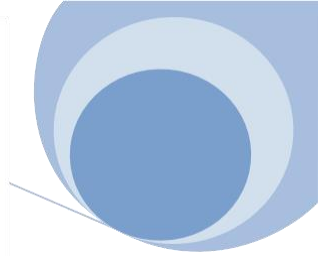

## Group of companies

- **Golden Link Industries LLC**
- **Golden Link Contracting & Decoration LLC**
- **Golden Lux General Trading FZC**
- **Super Golden Link Technical Works LLC**

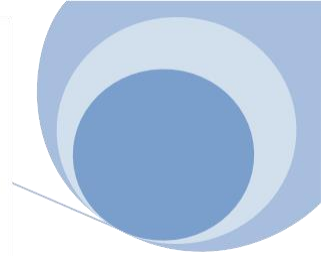

## Mission & Vision

**GOLDEN LINK** looks towards building a partnership with its customers in defining and implementing full life cycle Interior furnishing solutions that are timely, responsive, and cost effective. **GOLDEN LINK** team addresses very diverse customer needs, from cutting edge technology requirements. GOLDEN LINK deliverables conform to well-accepted international quality standards. The group endeavors to be the best in the industry.

### Our Vision

- To become the most preferred Organization for **Interior Furnishing, Designing & Kitchen Cabinets**

### Our Mission

- **Archive absolute customer satisfaction by taking care of project, providing quality service through standard operating procedures that meet the requirement of the customers.**
- **Leverage all efforts in focusing our activities to offer our services on time with competitive cost.**
- **Abide by the statutory and regulatory requirements applicable to our kind of concerns.**
- **Involve the work force at all levels to perform as a team to achieve the benefit of synergy.**
- **Build closer customer communication with all our clients to analyze their expectations.**
- **Always strive to maintain our consistent performance thereby achieving goodwill of customers.**

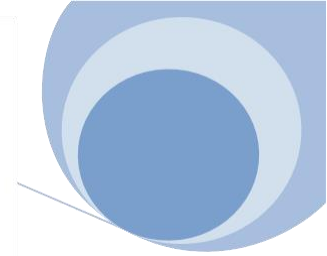

## Services Provided

### Construction

We provide a wide range of construction services to our clients in the **United Arab Emirates**. We are confident in delivering high quality construction projects through our expertise. We have already completed and delivered many successful projects across UAE in all sectors of infrastructure and real estate. We have a portfolio comprising of projects of all sizes and levels of complexity. We feel proud to be a part of the developments of **Dubai**.

we concentrate on the needs of the customers and their various requirements every time. We have skilled, professional and well experienced team and state - of - the art equipment with us to meet the customers' requirements and achieve optimum result. We take tasks right from initial business deals, designs, procurement and to delivery and also maintenance as well. We are able to tackle any unforeseen challenges during large construction works and provide solutions for the same. At the same time we also assure that the tasks are done within the given schedule and the budget limit. We proudly claims that we make no compromises in the standard of the provided.

### Electro Mechanical

We are specialized in executing electro- mechanical works in residential and industrial areas. We have done electrical and mechanical works for commercial buildings and also in huge factories. We company deal with supply, installation, testing and commissioning of electromechanical solutions such as cooling systems, air- conditioning, ventilation systems, plumbing works, drainage, firefighting systems etc.

We have the knowledge and all the facilities and make best use of technologies. Our expertise can be viewed from the wide variety of tasks we have handled and we have successfully completed some of the major projects in **UAE**. While providing such works, we also make sure that the quality is of world class. We always strive to do the service that meets the client's requirements and expectations. We have technical and design team



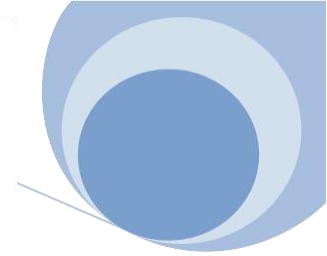

and well experienced artisans and qualified professionals for doing the job. Their constant efforts have gained our company a good reputation.

## Furniture & Custom Made Joinery

We manufacture custom made furniture for the home or business. We provide procurement, installation and maintenance for all the furniture requirements in **Dubai**. We have well experienced and qualified team for installing these furniture across any type of interior construction sectors. Based on the latest and modern trends, we have a large collection of office as well as home furniture. We design as per the requirements of the clients whatever it may be. The products we provide are of supreme quality and variety styles and at the same time affordable to the clients.

The office furniture includes workstations, office tables, chairs, cupboards, partitions, cabins etc. and can be designed according to the needs and requirements of our customers. The furniture included loose furniture, fixed furniture, doors, panels and frames etc. we make sure that the vision of the clients are incorporated in the products we make. We also assure the customers that the products are delivered within the specified time.

## Interior Design

We have more than 15 years of experience in **Interior Decoration** sector at various leading shopping mall in **Dubai, Sharjah** and **Abu Dhabi**. We have a wide variety of unique concepts in interior designing which enriches your lifestyle and provide you a new way of artistic discovery. Using right colors for designing gives a soothing effect to the client and also a peace of mind. Attractive and beautiful furnishings, relaxes the body and are sure to give a luxurious nature to your dazzling property. We are very grateful to be associated with some of the best furnishing companies in the world. We are proud and very much excited to introduce our clients a new world class **Lifestyle** beyond their expectations.

As a Dubai based company, we ensure our clients to deliver the best with our experience in this trade, planning skills and skilled labours to execute the plans at reasonable cost. Our aim is to provide high quality work in time and in perfection and to guarantee maximum to our clients and consultants.

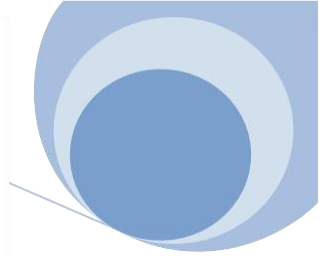

## **Kitchen Cabinet & Fit-Out**

**GOLDEN LINK** Industries has earned a reputation by manufacturing kitchens that are thoughtfully designed technology incorporated, meticulously executed to nestle where ever it is. Either in **Flats, Apartments, Villas** etc. the flavors of daily life begin from the kitchen in any human habitat and we see that with the popularity of the food outlets, the culinary magazines and just from a retail perspective with the popularity of kitchen gadgets and high style serve ware and entertaining ware.

Not to say that kitchens today are more than just cooking. It really is the hub and the heart of the Home, where families gather, people entertain, the children do homework, and in fact it represents the soul of inmates.

So we think that most families today really want to create a kitchen that will support their lifestyle needs. And to make the dreams come true for that home that they've wanted to have for quite some time.

### **Products**

- **Kitchen**
- **Authentic**
- **Traditional**
- **Modern**
- **Contemporary**
- **Appliances**
- **Doors**
- **Pergolas**
- **Wardrobes**
- **Vanities**

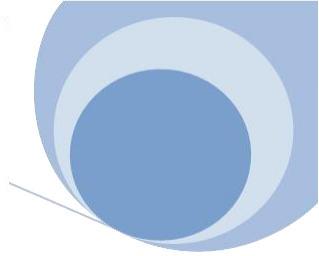

### **Authentic:**

To mould out elegance and create a timeless space, offsetting the graceful design for a comfortable ambience. A mix of natural materials makes for a practical but very attractive workstation.

### **Traditional:**

Familiar and friendly, creating a welcoming home front offers the ultimate warmth of our tradition matched with an eye appeal carrying the formal simplicity of its traditional roots.

### **Modern:**

Freshness and vitality that defines the modern kitchen which leaves behind the most striking effect, ultimate flexibility used to create depth and perfect balance of high tech infused with style & accessorized with exclusive products in any form.

### **Contemporary:**

Something special, a Kitchen to cook at, cook in & live with, striking with your favorite color palette & matched with simplicity and style.

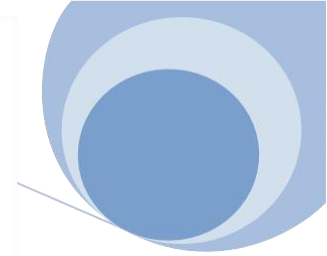

## Led Lighting

Mostly people leave the lighting jobs for the last minute. Whether it be Flat, Villas, Apartments or even offices, designing the lighting is usually kept as last works as everyone just wants to get the job finished soon and are tired unfortunately it is at this time that hasty decision are made which make them regret later.

Lighting the interiors are as important as other works and must be considered along with space planning and decorations planning. Unless a proper lighting technique is provided the interior designing becomes incomplete. Poor selection of lighting can wash out color and texture, making the room look like an ordinary one. On the other hand, providing a proper lighting technique can enhance and beautify even a simple interior decoration.

We are proud to provide the best lighting selection for your property. We can advise and assist you in planning the proper lighting designs for the clients. The clients / customers can feel free to contact us for providing professional assistance this field.

## Supervision

We also provide supervision of the various projects we undertake. It includes both design supervision and construction supervision. We have qualified operations supervisor for taking care of this sections in the interior projects done across Dubai. The design to be executed are supervised by the professional team. The construction supervisors do on- site supervision and follow up the orders and works. The furniture and other services provided are inspected properly and the delivery of the same and its installations are supervised to ensure high quality finish. We make sure that the projects are done as per the layout and designs and that the projects are executed efficiently.

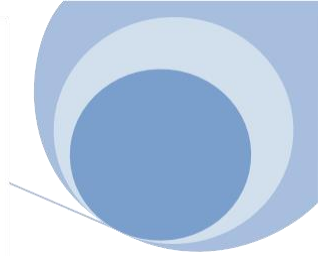

## Quality Policy

To provide high performance, defect free and cost effective **Interior Furnishing** solutions to all our customers using state- of the- art systems and technologies

***Authentication to requirements***

***Degree of excellence***

***Value perceived by customers***

At **GOLDEN LINK**, Managing Quality is

- **Identifying the requirements**
- **Understanding the zero defects, using prevention**
- **Developing team work**
- **Measuring to improve**
- **Identifying and analyzing problems**
- **Eliminating problem cause**
- **Improving customer / Dealer / Supplier relations**

At **GOLDEN LINK**, Quality Planning is

- **Product planning**
- **Managerial and operational planning**
- **Preparation of quality plans**
- **Making provisions for testing and quality improvement**

At **GOLDEN LINK**, Quality Control is

- **Process monitoring**
- **Eliminating the cause of unsatisfactory performance at all stages**

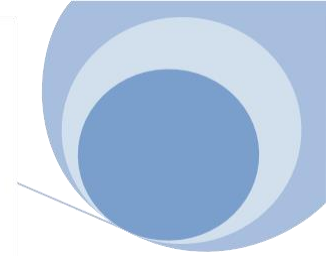

## Health And Safety Policy

**GOLDEN LINK** recognizes that good health and safety management have in the past, and continue to play an important role in the production of its quality products and general business growth.

It is our policy at **Golden Link** to ensure that at all times, we fulfil our obligation to meet the requirements of all relevant Health and Safety regulations and provide a conducive working environment for our employees.

In line with our Health and Safety management policy, we at **Golden Link** strive to:

- ✓ **Identify assess and manage the health and safety risks arising from our work activities.**
- ✓ **Arrange for safe use, handling, transportation storage and disposal of dangerous substances and materials as per regulatory and international standards.**
- ✓ **Provide and maintain safe plant and equipment.**
- ✓ **Carry out regular supervision, review and training to employees.**
- ✓ **Consult with our employees on matters affecting their health and safety.**
- ✓ **Prevent accidents and cases of work – related ill health**

Safety glasses and safety foot wear must be worn for all tasks. A dust mask / Respirator is required when work is being performed indoors, where there is no local exhaust ventilation or the ventilation is insufficient to protect from inhaling different dusts during process of different type of works. Other personal protective equipment (PPE) such as hard hats, aprons or overalls may be required depending on work activities.

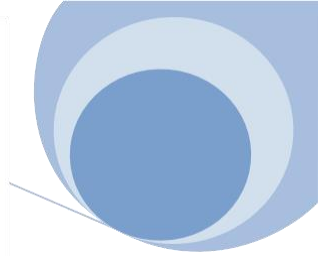

## Responsibilities

The company maintains overall responsibility for the health and safety of its workers and in ensuring that this policy is effectively practiced. All Employees and clients have a legal responsibility to:

- **Cooperate with managers and supervisors on health and safety Matters.**
- **Avoid interference with safety equipment and procedures put in place.**
- **Take reasonable care of one's own health and safety.**
- **Report all health and safety concerns.**

## Workshop Machine list

**Our top brand machines have earned us nationwide recognition due to advanced engineering, flexibility, and long –term reliability.**

No	Name of machine	Name of manufacturer	Origin
<b>01</b>	Fully automatic Panel Saw	SCM	Germany
<b>02</b>	Sliding table Panel Saw	Altendorf	Germany
<b>03</b>	Fully Automatic Edge Banding Machine for Solid Wood, PVC, Melamine, Abs Lipping	Holzher	Germany
<b>04</b>	Lipping trimming Machine for Curved Panel	Brandt	Germany



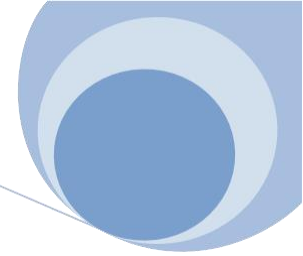

<b>05</b>	CNC machine center Touting, Boring, Profiling, Grooving, Rebating etc.	SCM / Sigma	Italy
<b>06</b>	Automatic CNC Boring Machine (Skipper)	Blumax	Germany
<b>07</b>	Panel Boring Machine (Semi-Automatic)	ELU	Germany
<b>08</b>	Hinge Boring Machine	Blumax	Germany
<b>09</b>	Carcass Assembly Press	Orma	Italy
<b>10</b>	Automatic Membrane Press For PVC Wrapping		Turkey
<b>11</b>	Drawer Box Assembly Press	JOS	Italy
<b>12</b>	Single Daylight Lamination Press	JOS	Italy
<b>13</b>	Automatic 4 Head Molder	Weigning	Germany
<b>14</b>	Band Re Saw	Sagotario	Italy
<b>15</b>	Surface Planner	Holzher	Germany
<b>16</b>	Thickness Planner	Holzher	Germany
<b>17</b>	Milling Machine For Door Frame	Holzher	Germany
<b>18</b>	Spindle Molder	Holzher	Germany



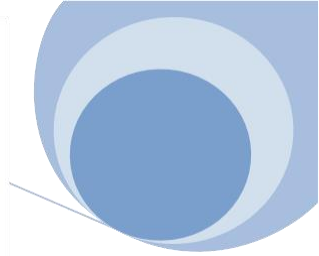

## Legal Status

Legal Name : **Golden Link Contracting & Decoration LLC**

Type : **Limited Liability Company**

### **Registered Office**

Tel : **+971 4 3885425**

Fax : **+971 4 388 5426**

Office : **Warehouse # 5, Sana Street,  
Ras Al Khor industrial area # 1,  
PB NO. 43262, Dubai, UAE**

### **Factory**

Tel : **+971 72444377**

Fax : **+971 72444378**

Office : **PB No. 14532, Ras Al Khaimah, UAE**

### **Bank**

Bank Name : **RAK BANK**

Account No : **0088487772061**

### **Owner**

Name of Owner : **Mr.Madhu Krishnan**

Mobile : **+971 50 6743160**

Activity : **conceptualize, Design & Build Turnkey  
Interior Fit Outs.**

**Conceptualize, Design, Manufacture and  
supply of Furniture.**

**Wooden Door / Kitchen Cabinet /  
Wardrobes / Wall Panels / Ceiling & all  
joinery items**

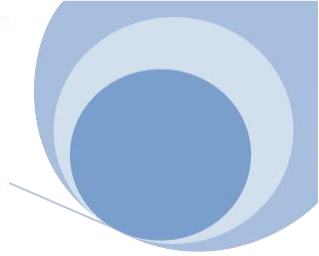

## Work Force

<input type="checkbox"/> <b>General Manager</b>	<b>:</b>	<b>1</b>
<input type="checkbox"/> <b>Project Manager</b>	<b>:</b>	<b>1</b>
<input type="checkbox"/> <b>Production Manager</b>	<b>:</b>	<b>1</b>
<input type="checkbox"/> <b>Contracts manager</b>	<b>:</b>	<b>1</b>
<input type="checkbox"/> <b>Admin &amp; Accounts Manager</b>	<b>:</b>	<b>1</b>
<input type="checkbox"/> <b>Engineers</b>	<b>:</b>	<b>4</b>
<input type="checkbox"/> <b>Project Coordinator</b>	<b>:</b>	<b>2</b>
<input type="checkbox"/> <b>Accountant</b>	<b>:</b>	<b>2</b>
<input type="checkbox"/> <b>Secretary</b>	<b>:</b>	<b>1</b>
<input type="checkbox"/> <b>Store Keeper</b>	<b>:</b>	<b>1</b>
<input type="checkbox"/> <b>Sales Team</b>	<b>:</b>	<b>5</b>
<input type="checkbox"/> <b>Draftsman &amp; designer</b>	<b>:</b>	<b>3</b>
<input type="checkbox"/> <b>Estimator</b>	<b>:</b>	<b>2</b>
<input type="checkbox"/> <b>Site supervisor</b>	<b>:</b>	<b>5</b>
<input type="checkbox"/> <b>Electricians</b>	<b>:</b>	<b>4</b>
<input type="checkbox"/> <b>Carpenters (finishing ) site</b>	<b>:</b>	<b>22</b>
<input type="checkbox"/> <b>Gypsum Carpenters</b>	<b>:</b>	<b>13</b>
<input type="checkbox"/> <b>Polishers &amp; Painters</b>	<b>:</b>	<b>16</b>
<input type="checkbox"/> <b>Glass Workers</b>	<b>:</b>	<b>3</b>
<input type="checkbox"/> <b>Masons</b>	<b>:</b>	<b>3</b>
<input type="checkbox"/> <b>A/C Technician</b>	<b>:</b>	<b>1</b>
<input type="checkbox"/> <b>Drivers</b>	<b>:</b>	<b>4</b>
<input type="checkbox"/> <b>Office Boy</b>	<b>:</b>	<b>1</b>

ORGANIZATIONAL CHART

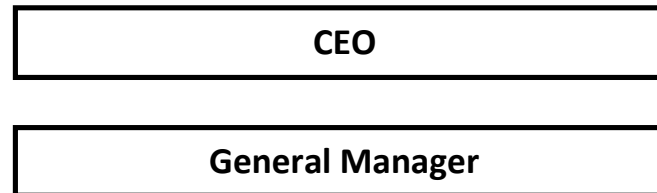

Accounts & Admin	Sales	Contracts	Projects	Production (Joinery)	Purchase
Manager	Manager	Manager	Manager	Manager	Manager
Senior Accountant	Sales Executives	Estimators	Project Coordinators	Factory Supervisor	Logistics & Purchase Executive
Accountants	Sales Reps	Designers	Project Supervisors	Foremen	Vehicle In charge
Assistants		Draughtsman	Project Foremen	Foremen	Drivers
			Charge-hands	Charge-hands	
			Skilled & unskilled Operators	Skilled & unskilled Operators	











## رخصة تجارية Commercial License

### تفاصيل الرخصة / License Details

License No.	541428	رقم الرخصة
Company Name	GOLDEN LINK CONTRACTING & DECORATION L.L.C	اسم الشركة
Trade Name	GOLDEN LINK CONTRACTING & DECORATION L.L.C	الإسم التجاري
Legal Type	Limited Liability Company(LLC)	الشكل القانوني
Expiry Date	20/01/2018	تاريخ الإصدار
D&B D-U-N-S ® No.	561231023	رقم الرخصة الام
Register No.	63693	عضوية الغرفة
	تاريخ الإنتهاء	Issue Date
	الرقم العالمي	Main License No.
	رقم السجل التجاري	DCCI No.
		ذات مسئولية محدودة
		21/01/2003
		541428
		74760

### اطراف الرخصة / License Members

Share / الحصص	Role / الصفة	Nationality / الجنسية	No./رقم الشخص	Name / الإسم
	Manager / مدير	India / الهند	162450	مادهو تاداتيل جوبالا كريشنان

### نشاطات الرخصة التجارية / License Activities

Building Contracting	مقاولات البناء
Floor and wall Tiling Works	اعمال تخطيط الارضيات والحوائط
Painting Contracting	اعمال الاصباغ والدهانات
Carpentry & Flooring Contracting	اعمال النجارة وتركيب الارضيات
Interior Decoration	اعمال تنفيذ التصميم الداخلي
Engraving & Ornamentation Works	اعمال النقش والزخرفة
Wall Paper Fixing	تركيب ورق الجدران
Partitions & False Ceilings Contracting	تركيب الاسقف المعلقة والقواطع الخفيفة

### العنوان / Address

Telephone	971-4-3200590	تليفون	P.O. Box	43262	صندوق البريد
Fax	971-4-3332397	فاكس	Parcel ID	319-114	رقم القطعة
Mobile No	971-50-6743160	الهاتف المتحرك			مستودع رقم 01 ملك مؤسسة دبي العقارية جردبي -راس الخور الصناعية 2

### ملاحظات / Remarks

مقاولات بناء ارضي +اول فقط .  
تم نقل الموقع في 2017/01/08

Print Date 21/01/2017 8:55 تاريخ الطباعة Receipt No. 12500445 رقم الإيصال

Activity  
Owners

الجهات التي لها صلاحية  
متابعة أنشطة الرخصة

( وثيقة إلكترونية معتمدة وصادرة بدون توقيع من دائرة التنمية الاقتصادية. لمراجعة صحة البيانات الواردة في الرخصة يرجى زيارة الموقع (http://www.dubaied.gov.ae

(Approved electronic document issued without signature by the Department of Economic Development. To verify the license kindly visit

http://www.dubaied.gov.ae



## ملحق الشركاء Partners

### تفاصيل الرخصة / License Details

D&B D-U-N-S No.	® 561231023	الرقم العالمي License No.	541428	رقم الرخصة
--------------------	-------------	------------------------------	--------	------------

### اصحاب الرخصة / License Partners

Sr. No./مسلسل الشخص	الجنسية / Nationality	Name / الاسم
51.0000000 %	439008 الامارات / United Arab Emirates	هندادي محبوب / HANADI MAHBOUB KHAMIS خميمس
49.0000000 %	162450 الهند / India	مادهو تادانتيل جوبالا كريشنان

Print Date 21/01/2017 8:55 تاريخ الطباعة Receipt No. 12500445 رقم الإيصال

Activity  
Owners

الجهات التي لها صلاحية  
متابعة أنشطة الرخصة





# رخصة LICENCE

RAKIA 36 IZ1 12 07 0816

رقم الرخصة

License No.

صناعية  
INDUSTRIAL

نوع الرخصة  
License Type

المرخّص / Licensee شركة الوصلة الذهبية للصناعات ذ.م.م

GOLDEN LINK INDUSTRIES LLC

أصحاب الترخيص / Partners Name

شركة الوصلة الذهبية للديكور ذ.م.م

مادھو تھاداتیل جوہالا کریشنان

بوسکو للألمنيوم والزجاج ش.ذ.م.م

الإسم التجاري :

النشاط :

صناعة أثاث وتركيبات المطابخ

مادھو تھاداتیل جوہالا کریشنان

اسم المدير /

Madhu Thadathil Gopala Krishnan

Manager Name /

شركة ذات مسؤولية محدودة

الشكل القانوني /

Limited Liability Comopany

Legal Status /

بيانات موقع العمل

المنطقة - الجزيرة الحمراء

Area

مالك العقار هيئة رأس الخيمة للإستثمار

Real Estate Owner

هاتف 07 2444377

Tel

Issue Date

05/12/2007

تاريخ الإصدار :

Renewed On

30/11/2016

تاريخ التجديد :

Amended On

تاريخ التعديل :

Expiry Date

04/12/2017

تاريخ الإنتهاء :

## Work Location Data :

العام

الشارع

Street

رقم العقار

Real Estate

فاكس

Fax

Issue Date

05/12/2007

تاريخ الإصدار :

Renewed On

30/11/2016

تاريخ التجديد :

Amended On

تاريخ التعديل :

Expiry Date

04/12/2017

تاريخ الإنتهاء :

رقم المكتب/ الشقة  
Office /Flat No

07 2444378



For Chief Executive Officer





رخصة تجارية  
Commercial License

تفاصيل الرخصة / License Details

License No.	697358	رقم الرخصة
Company Name	SUPER GOLDEN LINK TECHNICAL WORKS L.L.C	اسم الشركة
Trade Name	SUPER GOLDEN LINK TECHNICAL WORKS L.L.C	الإسم التجاري
Legal Type	Limited Liability Company(LLC)	الشكل القانوني
Expiry Date	28/10/2017	تاريخ الإصدار
D&B D-U-N-S ® No.		رقم الرخصة الأم
Register No.	1124090	عضوية الغرفة
	تاريخ الإنتهاء	Issue Date
	الرقم العالمي	Main License No
	رقم السجل التجاري	DCCI No.
		225217

اطراف الرخصة / License Members

Share / الحصص	Role / الصفة	Nationality / الجنسية	No./رقم الشخص	Name / الإسم
	Manager / مدير	India / الهند	209022	مدهو نهاداتيل جوبيا لاکريشنان

نشاطات الرخصة التجارية / License Activities

Air-Conditioning, Ventilations & Air Filtration Systems  
Installation & Maintenance  
Plumbing & Sanitary Contracting  
Carpentry & Flooring Contracting  
Insulation Contracting  
Plaster & Cladding Works

تركيب أنظمة التكييف والتهوية وتنقية الهواء وصيانتها  
اصال التمديدات والتركيبات الصحية  
اصال النجارة وتركيب الارضيات  
تركيب المواد العازلة في الابنية والمنشآت المعدنية  
اصال البلاستر والتكسية

العنوان / Address

Telephone	971-4-3200590	تليفون	P.O. Box	43262	صندوق البريد
Fax	971-4-3332397	فاكس	Parcel ID	128-455	رقم القطعة
Mobile No	971-50-6743160	الهاتف المحمول			مكتب رقم 15 ملك احمد عبدالرحمن احمد المالک الخبيصي

الملاحظات / Remarks

Print Date 31/10/2016 16:39 تاريخ الطباعة Receipt No. 12435242 رقم الإيصال

Activity  
Owners

الجهات التي لها  
صلاحية متابعة أنشطة

( وثيقة إلكترونية معتمدة وصادرة بدون توقيع عن دائرة التنمية الاقتصادية، لمراجعة صحة البيانات الواردة في الرخصة برجاء زيارة الموقع <http://www.dubaided.gov.ae> )

(Approved electronic document issued without signature by the Department of Economic Development. To verify the license kindly visit

<http://www.dubaided.gov.ae>



ملحق الشركاء  
Partners

تفاصيل الرخصة / License Details

D&B D-U-N-S  
No.

الرقم القومي License No.

697358

رقم الرخصة

اصحاب الرخصة / License Partners

الإسم / Name	الجنسية / Nationality	مسئله الشخص / Sr. No.	نسبة / %
HANADI MAHBOUB KHAMIS / هندي محبوب خميس	الامارات / United Arab Emirates	439008	51.0000000 %
MOHAMMED HOSNY MOHAMMED / محمد حسنى محمد الحسينى	مصر / Egypt	642027	17.0000000 %
ELHUSSEINY / ملادو تهاداتيل جويبا لأكريشنان	الهند / India	208022	17.0000000 %
ABDEL NASER KAMAL MOHAMED SHEHATA / عبدالناصر كمال محمد شحاته	مصر / Egypt	642028	15.0000000 %

Print Date

31/10/2016

16:39

تاريخ الطباعة

Receipt No.

12435242

رقم الإيصال

Activity  
Owners

جهات التي لها  
صلاحية متابعة أنشطة

( وثيقة إلكترونية معتمدة وصادرة بدون توقيع من دائرة التنمية الاقتصادية. لمراجعة صحة البيانات الواردة في الرخصة يرجى زيارة الموقع (<http://www.dubaided.gov.ae>) )

(Approved electronic document issued without signature by the Department of Economic Development. To verify the license kindly visit

<http://www.dubaided.gov.ae>





# BSCIC Certifications Pvt. Ltd.

## Certificate Of Registration



QUALITY MANAGEMENT SYSTEM

This is to certify that:

**GOLDEN LINK CONTRACTING  
& DECORATION L.L.C.**

**M 14, BUSINESS VENUE BUILDING  
OUD METHA, P.O. BOX NO 43262, DUBAI  
UNITED ARAB EMIRATES**

Hereby granted the Certificate Number: **BN12386/12259:0415**

Subsequent to the **assessment** conducted on **05-Apr-2015** and the organization has been found to be operating a Quality Management System which complies with the requirements of

**ISO 9001:2008**

for the following scope :

**Providing Carpentry and Flooring Contracting Floor & Wall Tiling Work Partition  
and False Ceiling Contracting, Wall paper Fixing, Engraving & Ornamentation Work,  
Painting Contracting, Interior Decoration and Building Contracting**

Originally Registered: **16 Apr 2015**

Latest issue: **16 Apr 2015**

Expiry Date: **15 Apr 2018**

For **BSCIC CERTIFICATIONS PVT.LTD.**

Sanjay Seth  
Managing Director

Page 1 of 1



Validity of this Certificate is subject to Annual Surveillance Audits to be done Successfully on or before 05-Apr-2016 and 05-Apr-2017 resp. (In case if Surveillance Audit is not allowed to be conducted; this Certificate shall be Suspended/Withdrawn).

Please re-check the validity thereafter at

<http://bscic.com/admincontrol/certificatestatus.php> or [www.bsc-icc.com](http://www.bsc-icc.com)  
at REGISTRATION STATUS. This Certificate of Registration is granted subject to relevant provisions of the BSCIC Certifications PVT. LTD. Contract Terms & Scheme for Registration Form B 018 (Latest Version). Please see B 018 at our website [www.bsc-icc.com](http://www.bsc-icc.com).



**GOLDEN** *link*  
CONTRACTING & DECORATION L L C  
INTERIOR DESIGN | SUPERVISION | CONTRACTING



*"Interior Solutions.....from  
Concept to Creation"*

**PROJECTS**  
**&**  
**GALLERY**

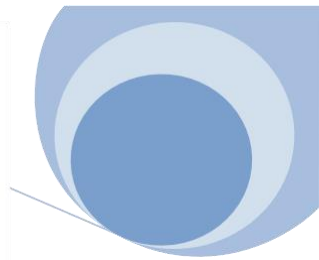

## Major Projects and Values

Sl no	Projects	Scope	Project value
1	Villas JLT	Joinery	2,100,000.00
2	Jumeirah Rotana Hotel	Joinery	6,900,200.00
3	Radisson BLU Ajman	Joinery	3,450,700.00
4	Living Legends- 100 Villas	Joinery	2,000,000.00
5	First Avenue Mall and Hotel	Joinery	5,800,000.00
6	Saadiyat Island Resort Abu Dhabi	Joinery	369,721.00
7	Fairmont Hotels and Resorts	Joinery	1,040,002.00
8	Sheraton, Abu Dhabi	Joinery	1,800,000.00

## Major Hotel Projects

- Rotana Hotel  
Jumeirah
- Le Royal Meridian
- First Avenue Mall & Hotel  
Motor City
- Radisson Blu  
Ajman
- Fairmont Hotel & Resort  
Fujairah
- Taj Palace Hotel
- Saadiyat Hotel & Resort  
Abu Dhabi
- Sheraton  
Abu Dhabi
- Ravis Center Point
- Jebel Ali Hotel
- Kempinski  
Dubai
- Flora Grand Apartments  
Dubai
- Raviz Center Point Hotel  
Dubai





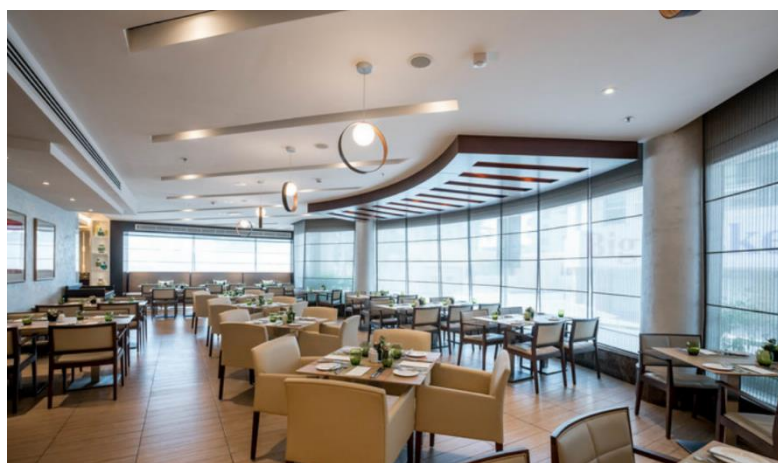
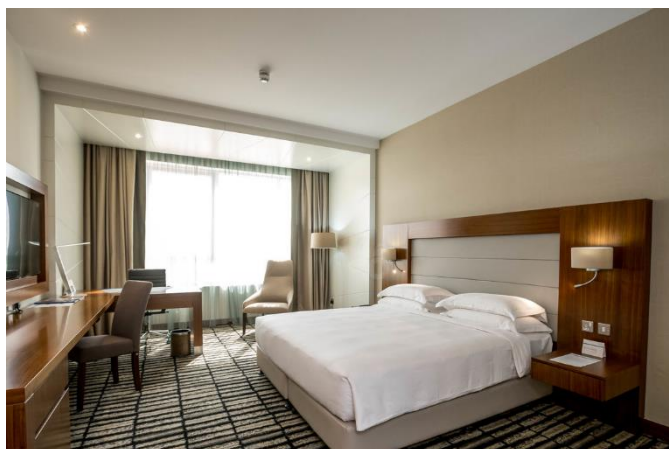
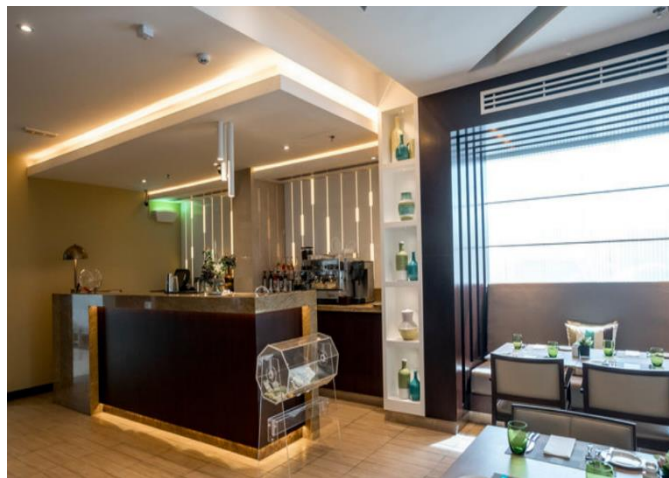

**JUMEIRA ROTANA HOTEL - FULL RENOVATION WORKS OF 110 ROOMS , LOBBY, RECEPTION, ALL DAY DINING, KING , QUEEN, SUIT, APARTMENT AND STANDARD GUEST ROOMS RENOVATION AND FF&E WORKS WITH CIVIL, MEP,SOFT AND HARD FURNISHING**





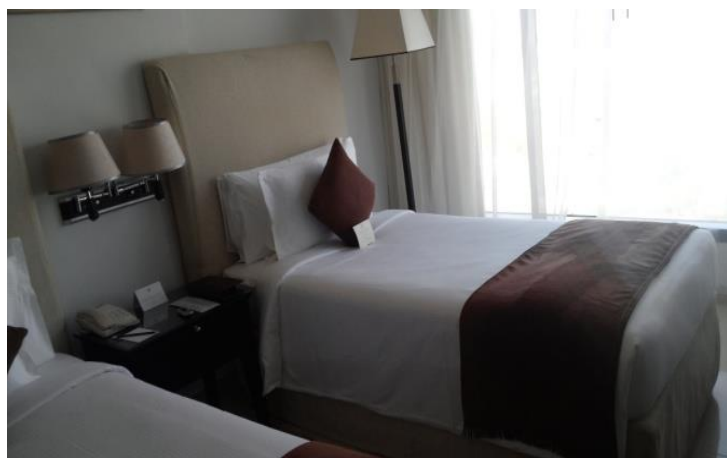

LE ROYAL MERIDIAN HOTEL - RENOVATION WORKS OF GUEST ROOMS WITH SOFT AND HARD FURNISHING





# First Avenue Mall & Hotel Motor City

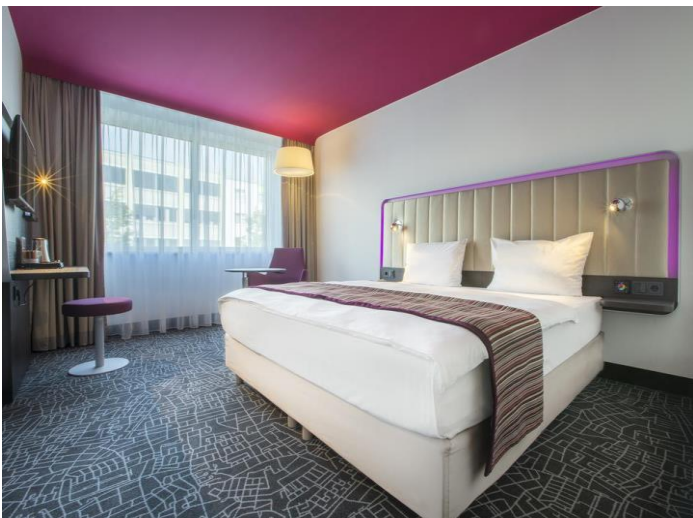



# Fairmont Hotel & Resort Fujairah

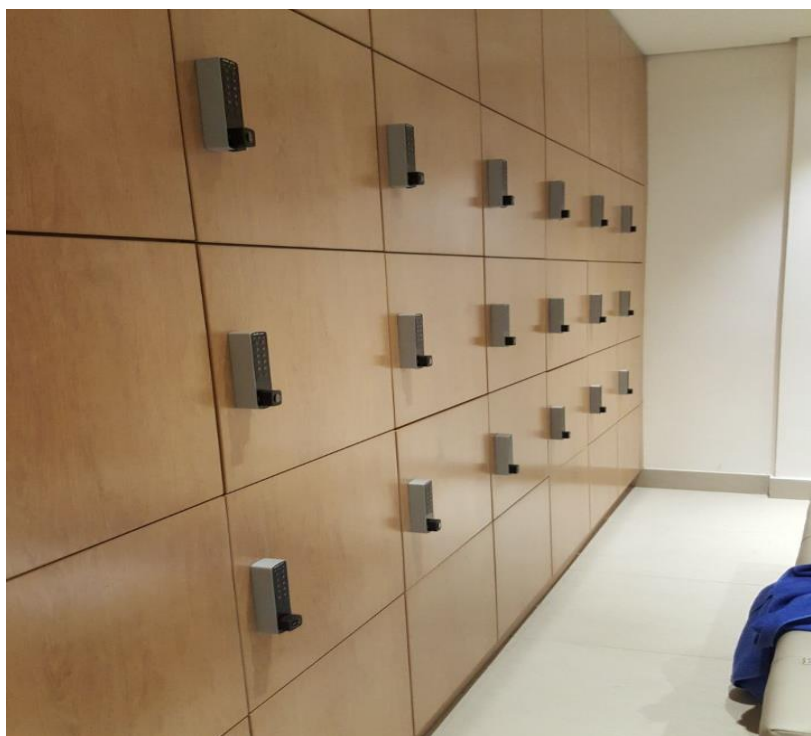

## Major Restaurant Projects

- Beilla Restaurant, Wafi Mall  
Dubai
- Holiday Beach Hotel  
Fujairah
- MacDonald' s  
Abhu Dhabi
- Jedoudna at JBR
- Picardo Caf é
- Deli-d-caf é
- Thai Time Restaurants
- Citadel Restaurant
- Zain Caf é
- Wild and Moon F & B
- Jumeirah Rotana Hotel  
Multiple Coffee shops and all  
day dining
- Shake Shack, Yas Island Mall  
Abu Dhabi
- Doner Deli, Marina Park Island  
Dubai Marina
- Ihop -Al Sufouh ,Dubai Marina
- Turbo Grill -Dubai Media City
- Chalhoub Group Canteen-D3  
Dubai
- Chalhoub Group Canteen,  
Jafza
- La Rouge Italia, Abu Dhabi
- Tila Liwa Hotel-Al Badiya  
Restaurant
- Layali-Tilal Liwa Hotel,Al  
Gharbia
- Abu Dhabi
- Yummy Indian
- Caf é Rider -Al Barsha  
Dubai















## Major Offices & Showrooms

- Renarte General Trading
- Grosvenor Business Tower
- International Management ventures FZ-LLC
- LBI Mena FZ L.L.C ,Al Shatha Tower
- Grey Stone Trading DMCC  
Platinum Tower
- Deniz Asia Trading L.L.C  
Nassima Tower
- Republic of Ecuador ,Nouf Tower
- TLCA General Trading  
EmarathAtrium Tower
- Dubai Gold and Diamond Offices  
AU Tower
- Dubai Design District  
Building No 10 & 11
- American Express Media One Tower
- Elysees Beauty General Trading L.L.C
- Ice Berg Management L.L.C
- Starcom, Media Vest Group
- Peugeot Show rooms
- Majeelan Spare parts Showroom
- Great Wall Show rooms
- Good Year Showrooms
- Blue Ribbon
- Gitanjali Jewellers
- Dhamani Jewellers
- Dhalumaal Jewellers
- Layali Jewellers
- Algaronini Jewellers
- Al Sagar Jewellers
- Rani pal Jewellers
- Ladies Jewellers jewel & gems
- La marquise watches
- Abi Diamonds
- Venice Jewellers
- Ratan Sajan Jewellers
- Kamiasun Jewellers
- Sony dayal Jewellers
- Forever Diamonds
- Samra Jewellers
- Dia Emirates L.L.C
- Gulf Sports Media  
10TH & 20TH Floor Indigo Tower ,JLT
- Allied Enterprises Offices  
Burjuman 13<sup>th</sup>
- Aspin Holding L.L.C  
Aspin Tower 53rd Floor
- Style Avenue Offices  
Burjuman 16th Floor
- Cotty Offices Burjuman 24th Floor
- Chititilapilly Jewellers
- Chemmanur Jewellers
- Crystal Gallery Outlets
- Mahalati Jewellery







ASPIN TOWER ON SZR TURNKEY FITTOUT AND WOODEN JOINERY OF DOORS VANITY AND DECORTION WORKS









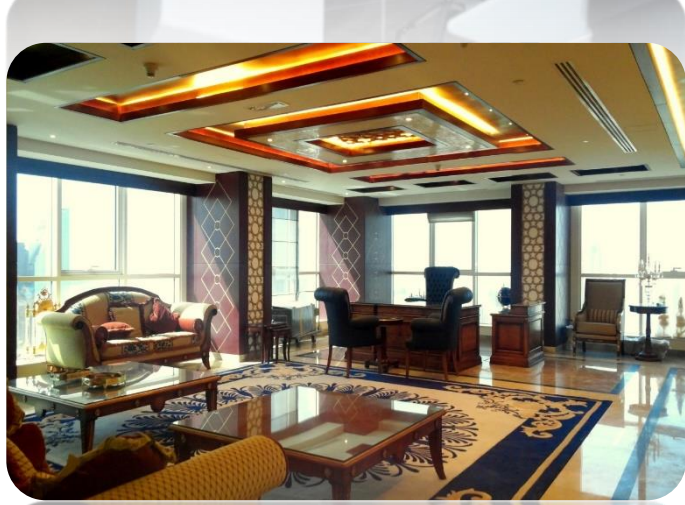







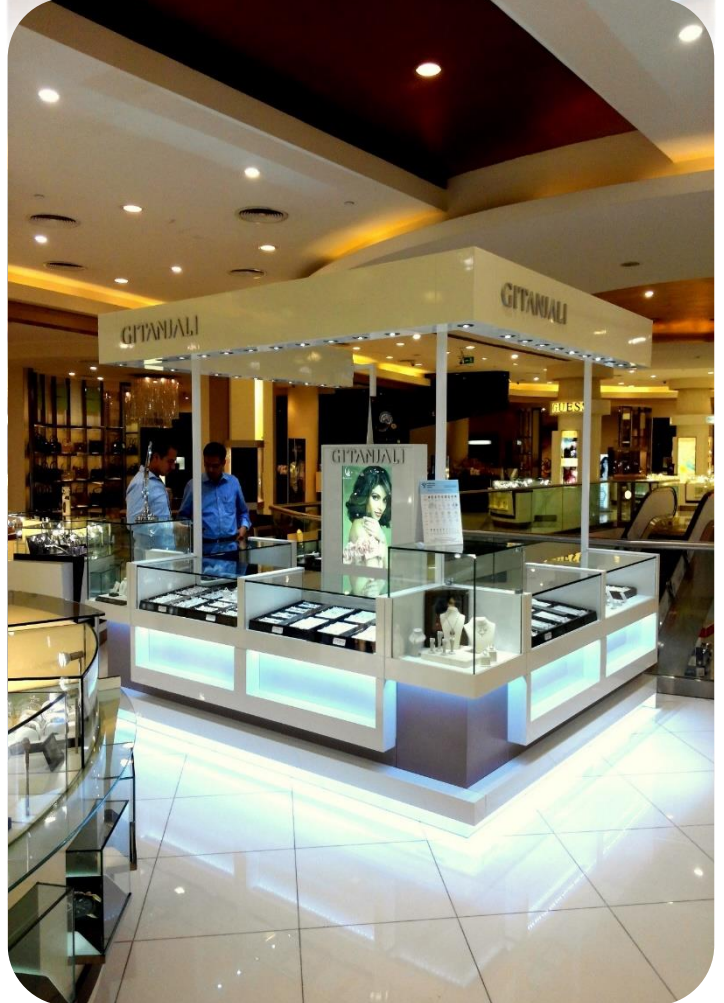





## Malls, Govt Authorities, Consultants worked with

- Dubai Mall
- Mall Of Emirates
- Yas Mall
- Abudhabi Mall
- Bin Soughat Centre
- Mazaya Centre
- Sahara Centre
- Union Cooperative Society
- Gold Centre
- Gold Land
- Aspin Tower
- Tecom
- Jafza, trakhees
- EMMAR
- NAKHEEL
- DWTC
- SEWA
- Dewa
- Deira City Centre
- Ajman City Centre
- Ibn Battuta



## Major Corporate Clients

- Tecom
- Dmcc
- Swaidan Trading
- Dubai Immigration
- TATA Consultancy Services
- Majelan Trading
- Autoban Car Rentals
- CGR
- Apollo Tyres
- Starcom
- American Express
- Juma Al Majid
- Gold & Diamond Group
- Mkm Commercial Holdings
- Design Decoration Display
- Rotana
- Dubai Customs
- MH Al Shaya
- Media West
- Design Decoration Display
- Chititilapilly
- Malaysian Industrial Development Authority
- Blue Ribbon L.L.C
- Gulf Commercial Cooperation
- Dhamani Jewels
- Daaraa Gold
- Dhalumal Gold Group
- Aedas Design
- GCCI
- MAF





# DELTA AL EMIRATES - AL BARRARI at DUBAI LAND LIVING LEGEND 500 VILLAS MAIN DOORS / INTERNAL DOORS / KITCHEN /VANITY AND WARDROBES









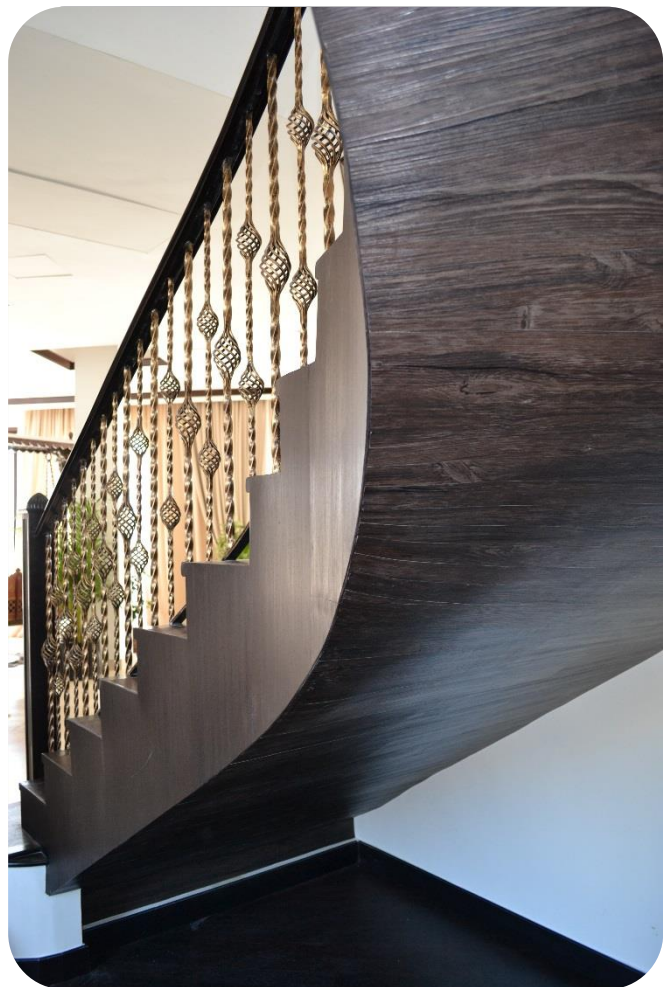





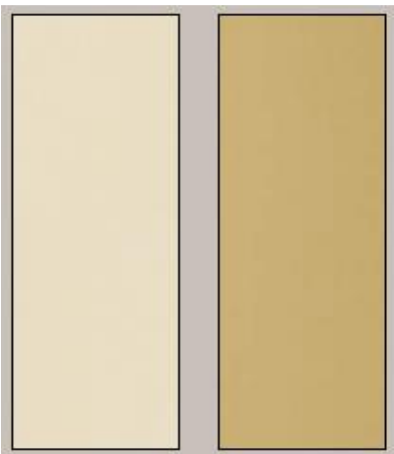
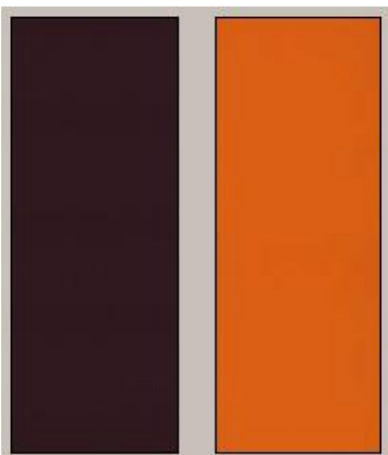







**Details of Projects Executed 2015 - 2016**

Sl. No	Projects	Location	Client/contractor
1	Gitanjali Jewellers	Almas tower - Dubai	Gitanjali jewellers
2	Gulf Sports media LLC	GSM indigo tower	3D design decoration & display
3	Blue Ribbon		Blue ribbon
4	Pro Ecuador office	Nouf tower - Dubai	Pro ecuador office
5	3D Design office work	Dubai	3D design decoration & display
6	Ranarte		Ranate hospital
7	Havas Digital Modification	Madia city - Dubai	3D design decoration & display
8	CGR WH1 Extention	Jebel ali - Dubai	3D design decoration & display
9	CGR WH1 Office Extention	Jebel ali - Dubai	3D design decoration & display
10	Restaurent Fit Out Work	Dubai	Village circle restaurent
11	CGR WH1 Office Extention	Jebel ali - Dubai	3D design decoration & display
12	Deniz Asia General Trading LLC	Nassima tower - Dubai	
13	Gitanjali Jewellers	Bawardi Mall	Gitanjali jewellers
14	Kiosk - P27	Adudhabi mall - abudhabi	Gitanjali jewellers
15	Kiosk - Alain Mall	Al ain mall - al ain	Gitanjali jewellers
16	Kiosk - Mirdif city	City center - Dubai	Gitanjali jewellers
17	Office Interior work		Electra living LLC
18	Chalhoub - Re-painting work	Jebel ali - Dubai	3D design decoration & display
19	Dubai gold & Jewellery group	Deira - Dubai	Mr.sunny chittilapilly
20	Aspin tower - Lift Flooring Work	Dubai	Al ashram contracting
21	Office - 502 (Modification Work)		Vainex FZCO
22	Havas WW ME Office Work	Media city - Dubai	3D design decoration & display
23	CGR office - Led lights work	Dubai	3D design decoration & display
24	CGR renovation works	Dubai	3D design decoration & display
25	Proposed gym / fitness	Dubai	Mr.yerlan seisembayev
26	Chalhoub office - LCD installation	Dubai	3D design decoration & display
27	Chalhoub office - Art podium work	Dubai	3D design decoration & display
28	CGR WH1 office	Dubai	3D design decoration & display
29	Havas WW ME office work	Media City - Dubai	3D design decoration & display
30	Aqualyng	Dubai Media city - dubai	Aqualyng resource management
31	CDC general trading	Burjuman Center - dubai	
32	Chittilapilly jewellers - DIP outlet		Mr.Sunny chittilapilly
33	Vog hair fixing saloon	Ibn Battuta mall	Al khaleej training & education
34	BJT 23rd floor - Parque flooring	Dubai	3D design decoration & display
35	Chalhoub office - renovation work	Dubai	3D design decoration & display
36	Level management office	Dubai Mall - Dubai	3D design decoration & display
37	Chalhoub office - renovation work	Dubai	3D design decoration & display
38	satcom - washroom renovation	Media City - Dubai	Starcom mediavest group
39	Sugandh - jewellers DMCC	Dubai	Sugandh management consultancy
40	L4301 loft @ executive tower	Dubai	JND interiors
41	L4301 loft @ executive tower	Dubai	JND interiors
42	Digital LBI	32 Floor, Shatha Tower - Dubai	L.B.I mena FZ- LLC
43	Lacoste marina mall	Dubai	Allied enterprises LLC
44	AWI company	Internet City - Dubai	Miss. Rita zahar
45	Bhaktiar villa	Dubai	Mrs. Alexandra D' ursal
46	The loft - 5th avenue	Dubai	Miss.Jacob hrayki
47	CGR - WH1 Office	Dubai	3d design decoration & display
48	Level management office	Dubai Mall - dubai	3d design decoration & display
49	Starcom 5th floor	Media City - Dubai	Starcom mediavest group
50	Starcom Villa -18	Media City - Dubai	Starcom mediavest group
51	2305 GBT	Dubai	IMV FZE LLC
52	Chalhoub Office - Renovation work	Dubai	3D design decoration & display
53	Chicking	Lulu mall - Ras Al Khaimah	Al bayan group of companies
54	Blue Ribbon		Blue ribbon LLC
55	AU tower 30F & G office - fitout	AU Tower - Dubai	Dubai golde & jewellery group
56	Office Renovation work		Majeelan
57	Starcom Villa - 08	Media City - Dubai	Starcom mediavest group
58	Fitt out Work - Europcar	Abudhabi	Mrs. Shabna Rajesh
59	Fitt out Work - Office-B&C-GBT		IMV FZE LLC
60	Chalhoub office-Renovation Work	Dubai	3D design Decoration & Display
61	Havas office- level 1	Dubai	3D design Decoration & Display
62	Arzanah helth point	Abudhabi	Broadway Interiors
63	Capital gate building	Abudhabi	Bell Helicopter
64	Marble slap cremery	Ibn Battuta Mall - Dubai	Dessert Rose Holding Hospitality

Details of Projects Executed 2017			
1	D-67 Villa	Palm Jumeirah - Dubai	Project architecture
2	Chalhoub - Water Proofing Work	Jebel Ali - Dubai	3D design decoration & display
3	Aspin 53rd Floor	Dubai	Aspin holding LLC
4	Allied Office @ BJT 13th floor	Dubai	3D design decoration & display
5	Pent House	Dubai	Project Architecture
6	Boutique - Villa 04 fittout work	Media City - dubai	Starcom Mediavest Group
7	Starcom Office	Media City - dubai	Starcom Mediavest Group
8	Pure gold Jewellers	Sahara Center- sharjah	Pure Gold
9	Starcom Villa - 11	Media City - dubai	Starcom Mediavest Group
10	BJT 24th floor Coty Emirates Office	Dubai	3D design decoration & display
11	Pure Gold Jewellers	Mercato mall , Jumeirah	Pure gold
12	Shake Shack	Abudhabi	Havelock AHI
13	Bell Heilcopter	KPS	Gypsum work
14	CGR office - Renovation works	jebel ali port , dubai	3D design decoration & display
15	Arzanah Health Point	Abudhabi	Brodway Intreiors
16	Boutique - Villa 14 Fit-out work	Media city - Duabi	Starcome
17	Palm Jumeira Villa	Dubai	Al Rostamani Pegel LLC
18	Botique - Villa 21 -Fitout Works	Media city - Duabi	Starcome
19	SEWA Control Office-Modification	Sharjah	Al Mostajed Tech. Co. LLC
20	Aspin Holding 41st Floor	Dubai	Ice Berg
21	Cara Jewellers - Main	GDP- Dubai	Cara Jewellers
22	AVI - Office	DIP	AVI
23	Yamaha	Dubai Mall - Dubai	Thomsun Pure Music (Br)
24	Beila Restaurant	Wafi Mall - Dubai	HSSC Interiors
25	RAK Hospitality Services	Khuzam, Ras Al Khaimah	HSSC Interiors
26	HAVAS	Media City, Dubai	3D design decoration & display
27	Wild & Moon - Juice Bar	Al Qouz, Dubai	Paris Juice Catering LLC
28	Cara Jewellers - Main	GDP- Dubai	Cara Jewellers
29	Bvlgari	Dubai Mall - Dubai	Gulf Luxury Trading LLC
30	Palm Residence Villa 81	Palm Jumeirah - Dubai	Nasser Investment LLC
31	Cara Jewellers - Exclusive	GDP- Dubai	Cara Jewellers FZC
32	Yellow Chilli Restaurent	Abu Dhabi	SMD Interiors
33	Radisson Blu Hotel	Ajman	Fairmount Contracting
34	Union Cooperative	Hamrya	Union Cooperative society
35	Al Barrari Villas	Dubailand - Dubai	Delta Engineering Contracting
36	Rotana Hotel	Satwa - Dubai	MKM Interiors
37	Villa @ Muhsinah	Dubai	Mr. Nawal Mohammed
38	Private Villa	Sharjah	Mrs. Maryam Sayed
39	Union Cooperative	Al Aweer - Dubai	Union Cooperative society
40	Union Cooperative	Al Wasal - Dubai	Union Cooperative society
41	Union Cooperative	Hamryia - Duabi	Union Cooperative society
42	Al Safeer Hotel	Fujairah	
43	Building D10 & D11-Chalhoub Group	Dubai Design District	Chalhoub Group
44	Bakery Kitchen	DIP - Dubai	Aubine
45	Building D11 - Canteen	Dubai Design District	Chalhoub Group
46	Jebel Ali Hotel - Partial Renovation	Jabel Ali, Dubai	Jabel Ali Hotel
47	Le Meridian - Partial renovation	JBR - Dubai	Le Meridian
48	Flora Apartments - Partial Renovation	Dubai	Flora Apartments
49	Al Wasl Properties - Partial Renovation	Dubai	Al Wasl Properties
50	Taj Place - Partial Renovation	Dubai	Taj Palace
51	Flora Grant Hotel - Partial Renovation	Dubai	Flora Grant Hotel
52	Thomsun	Sharjah	Thomsun/ Yamaha
53	Kiosk	Ras Al Khaimah	Autobahn

Current projects			
1	First Avenue Hotel	Motor City - Dubai	Arco Interiors
2	Saadiyat Hotel & Resort ,Abudhabi	Abudhabi	Ghantoot Transport and General Contracting L.L.C
3	G+4P+15 JVC Residential Tower	jumeirah village circle, Dubai	Royal International Construction L.L.C.
4	Fairmont Hotel & Resort	Fujairah	Sinyar Al Khaleej Contracting
5	B+G+4+R Hotel	IMPZ, dubai	Al safeer group
6	Meeting room & coffee shop	IMPZ, dubai	Al safeer group
7	Manthaka villa	Ras Al Khaimah	The Private Office of H H Sheikh Dr. Sultan Bin Khalifa Bin Zayed Al Nahyan
8	Majlis villa	AL SAFOUH, DUBAI, UAE	H H Sheikh Dr. Sultan Bin Khalifa Bin Zayed Al Nahyan
9	MCT -HO1 office	Jebel Ali	Chalhoub Group
10	The Dubai mall zabeel expansion	Dubai mall, Dubai, UAE	M/s: Sharif interiors LLC.
11	Arabian villa	Abu Dhabi	Arco Interiors

**GOLDEN** *link*  
CONTRACTING & DECORATION L L C  
INTERIOR DESIGN | SUPERVISION | CONTRACTING



*"Interior Solutions.....from  
Concept to Creation"*

# **SUBMITTALS & DRAWINGS**

FAM-PIV-BLD-MAT-CIV-377 Rev-00

# Material Submittal for CABINET HARDWARE

M/s ARCO Interiors

THE FIRST AVENUE MALL & HOTEL  
Al Hebaiah First, Dubai UAE



**Dewan**  
Architects –  
Engineers

**PIVOT**  
ENGINEERING & GENERAL CONTRACTING

**Issue Approval:**



Issue: 01      Revision: 00  
Name:        Sufian A. Ahmad  
Signature

Issue Date: 31/12/2016  
Title: Sr. Project Manager

THIS IS A CONTROLLED DOCUMENT.  
NO COPYING WITHOUT PERMISSION

Controlled Copy Number:



	<b>Dewan</b> Architects + Engineers	<h2 style="text-align: center;">Material Compliance Statement</h2>		Document No. SS-FOP-124-FT19 Issue Date: 27/8/2014 Rev: 0 Rev'd EF App'd FS Page 1 of 3
Project: THE FIRST AVENUE MALL & HOTEL			Consultant: DEWAN ARCHITECTS + ENGINEERS	Client: AL TAWFEEQ FOR DEVELOPMENT & INVESTEMENT
Material Specification Reference: 06 41 93	Material Submittal No.: 070	Rev. : 00	Date: 17-Dec-2016	
<b>General Description of Material:</b> • <b>CABINET HARDWARE</b> 06 41 93.03 <b>Wardrobe door knob</b> Hafele ref: 135.71.901, silver anodized, W12XH12XD25MM 06 41 93.07 <b>Pull down clothing rail</b> Hafele ref: 805.20.324 Black arm and clothes rail; Nickel plated 06 41 93.08 <b>Wardrobe rail with LED light sensor, 12V</b> Hafele ref: 833.11.901 08 71 00.11 <b>Duomatic concealed hinges</b> Hafele ref: 329.17.903 <i>Additional Hardware required for the cabinet as proposed are listed below for consultants reference:</i> * <b>Drawer Runner- Ball bearing runners</b> Reference code: 741-7.42 * <b>Connecting screw and sleeve</b> Reference code: 267.06.722 * <b>Wardrobe hooks</b> Reference code: 842.58.000 * <b>Ventilation Grills</b> Reference code: 571.78.1041 * <b>Econo Cylinder lock</b> Reference code: 234.99.261	<b>Area of use:</b> 06 41 93.03 Guestrooms 06 41 93.07 Disabled 06 41 93.08 Guestrooms 08 71 00.11 SPA & Gym	<ul style="list-style-type: none"> <li>• Wardrobe door knob - All Cabinet unit</li> <li>• Pull down clothing rail – Cabinet unit @ disabled room</li> <li>• Wardrobe rail with LED Light sensor- All cabinet Unit in Guestroom</li> <li>• Concealed Hinges - All Cabinet unit shutter &amp; wardrobe shutter</li> <li>• Plug Fit Push Door Catches- All Cabinet unit shutter &amp; wardrobe shutter</li> <li>• Drawer Runner- Ball bearing runners All Wardrobe, reception counter, Service Station</li> <li>• Connecting screw - All Wardrobe</li> <li>• Wardrobe Hooks - All Wardrobe</li> <li>• Ventilation Grill - Desk with mini bar units</li> <li>• Econo Cylinder lock - Reception counter</li> </ul>		
Subcontractor: ARCO Interiors		Supplier: ARCO Interiors		
Manufacturer: JOINERY CONTRACTOR		Brand Name: Joinery Contractor		

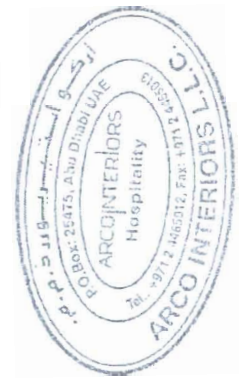







WAFI PROJECTS  
MKM HEAD OFFICE



Devon

MAS-55

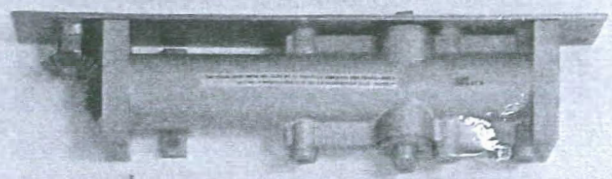

DOOR CLOSER

MAS 2-25/17

WAFI PROJECTS  
MKM HEAD OFFICE  
01 JUN 2016  
RECEIVED

PAINT FINISH FOR BACK FILING UNIT



DOOR HANDLE

MAS 30

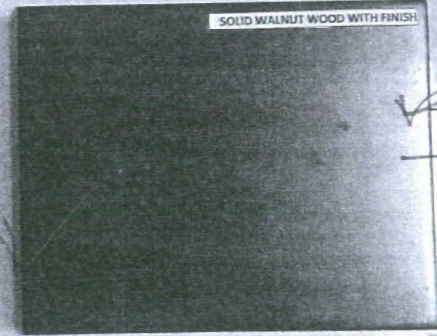

SOLID WALNUT WOOD WITH FINISH

MAS 54

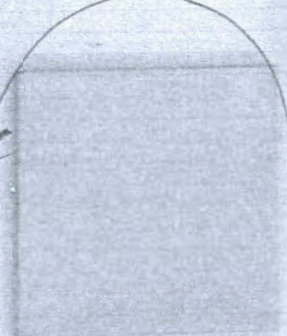

RAFFAELLO STUCCO

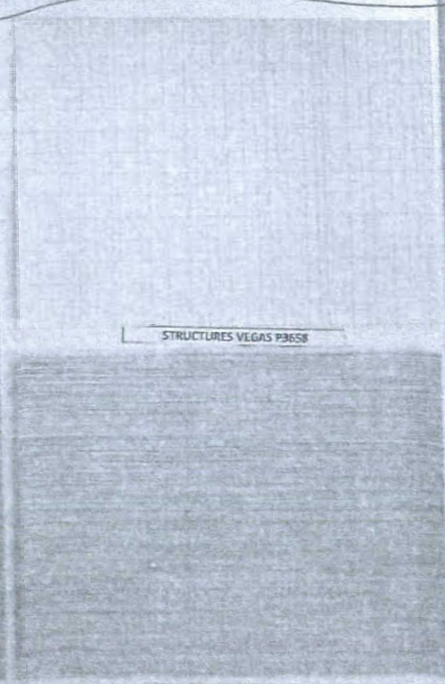

STRUCTURES VEGAS PRESS

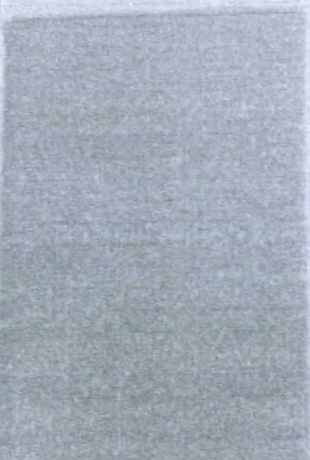

STRUCTURES PRAIRIE 03A46



CHANCERY TESSAL 03A45



UNION CANTON 09A48



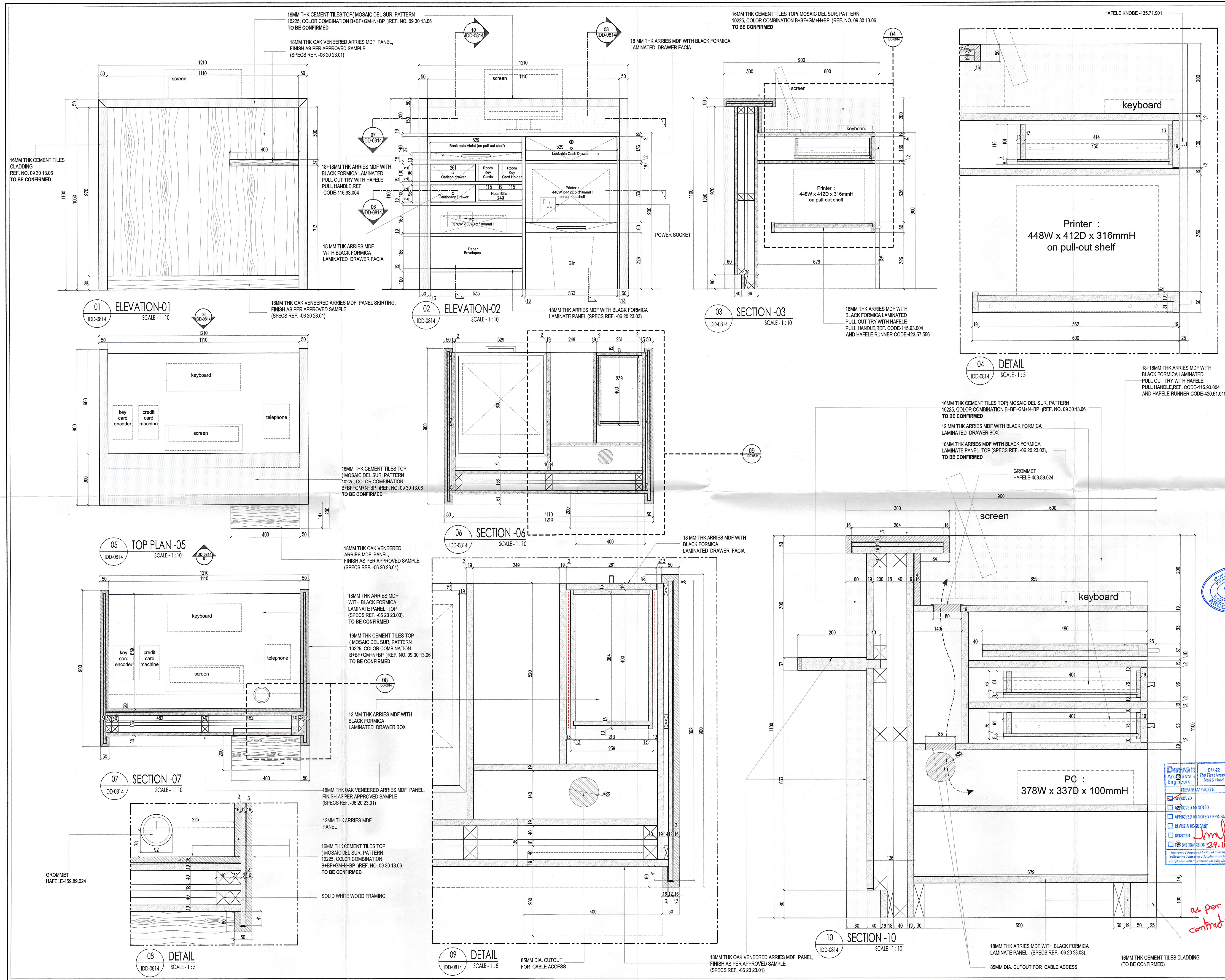

**KEY PLAN:**

RECEPTION POD - FF001

FIRST FLOOR LOBBY & LOUNGE

**GENERAL NOTES:**

THIS DRAWING IS THE COPYRIGHT OF ARCO INTERIORS AND MUST NOT BE RETAINED, COPIED OR USED WITHOUT ARCO INTERIORS AUTHORITY.

DO NOT SCALE FROM THIS DRAWING.

ALL DIMENSIONS ARE IN MILLIMETERS UNLESS INDICATED OTHERWISE.

THIS DRAWING SHOULD BE READ IN CONJUNCTION WITH OTHER RELEVANT DESIGN, STRUCTURAL, MECHANICAL & ELECTRICAL DRAWINGS AND ALL RELEVANT SECTIONS OF THE SPECIFICATIONS.

ALL DIMENSIONS ARE TO BE CHECKED ON SITE PRIOR TO ANY WORKS BEING PUT IN HAND.

ANY DISCREPANCIES IN THE DRAWING ARE TO BE BROUGHT TO THE IMMEDIATE NOTICE OF THE DESIGNER.

**LEGEND:**

**REFERENCE DRAWINGS / DOCUMENTS:**

**IFC DRAWINGS:**

REV.	DWG./DOC. NO.	DESCRIPTION
C0	ID-CS-8-4.01	RECEPTION POD - FF001

**SHOP DRAWINGS:**

REV.	DWG./DOC. NO.	DESCRIPTION
00	FAM-PIV-MAH-SPD-ID-0381	FIRST FLOOR LOBBY ENTRANCE/ LOUNGE GENERAL ARRANGEMENT LAYOUT

**RFI REFERENCES:**

RFI NO.

**REVISIONS:**

REV.	DATE	DESCRIPTION	DRAWN	CHKD.
00	16-11-16	ISSUED FOR APPROVAL	SUDHI	NA

**CLIENT**

**CONSULTANT**

**Dewan Architects + Engineers**

P.O. BOX 60990 DUBAI, UNITED ARAB EMIRATES  
TEL: +971-4-3958566 FAX: +971-4-3958900  
E-MAIL: duba@dewan-architects.com

**MAIN CONTRACTOR**

**PIVOT**  
ENGINEERING & GENERAL CONTRACTING

**SUB CONTRACTOR**

**ARCO INTERIORS**

UAE ABU DHABI, P.O. BOX 25475, TEL: 02-4665012 / FAX: 02-44665013  
www.arcointeriors.com

**PROJECT NAME AND LOCATION**

**THE FIRST AVENUE MALL & HOTEL**  
PLOT NO: 6742010  
AL HEBALIAH FIRST, DUBAI, UAE

**ID SHOP DRAWING**

Dwg. title :-  
TYPICAL RECEPTION POD-FF001 DETAILS  
LOCATION - FIRST FLOOR LOBBY ENTRANCE/LOUNGE  
TOTAL QUANTITY - 2 NOS.

Date	Drawn	Scale	Chkd.	Appd.
08-11-16	SUDHI	AS SHOWN	NA	-

Dwg. no: FAM-PIV-MAH-SPD-ID-0814

Rev. no: 00

*as per contract*



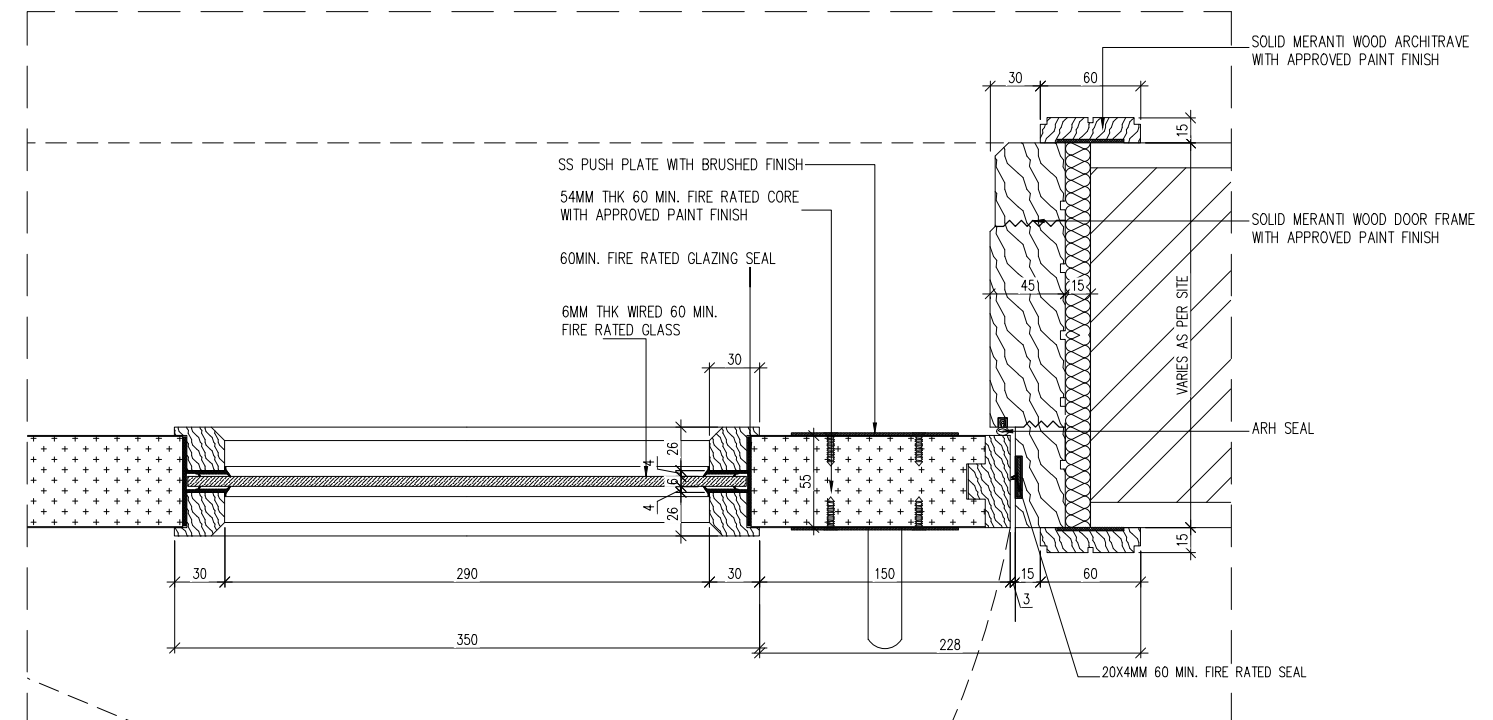
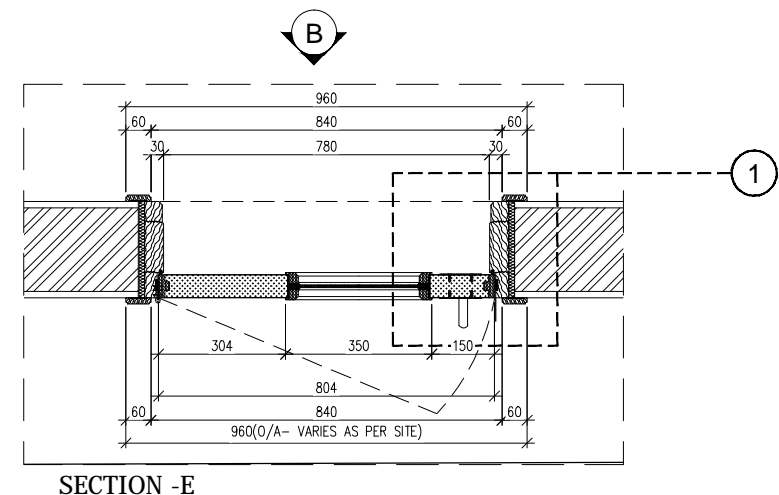
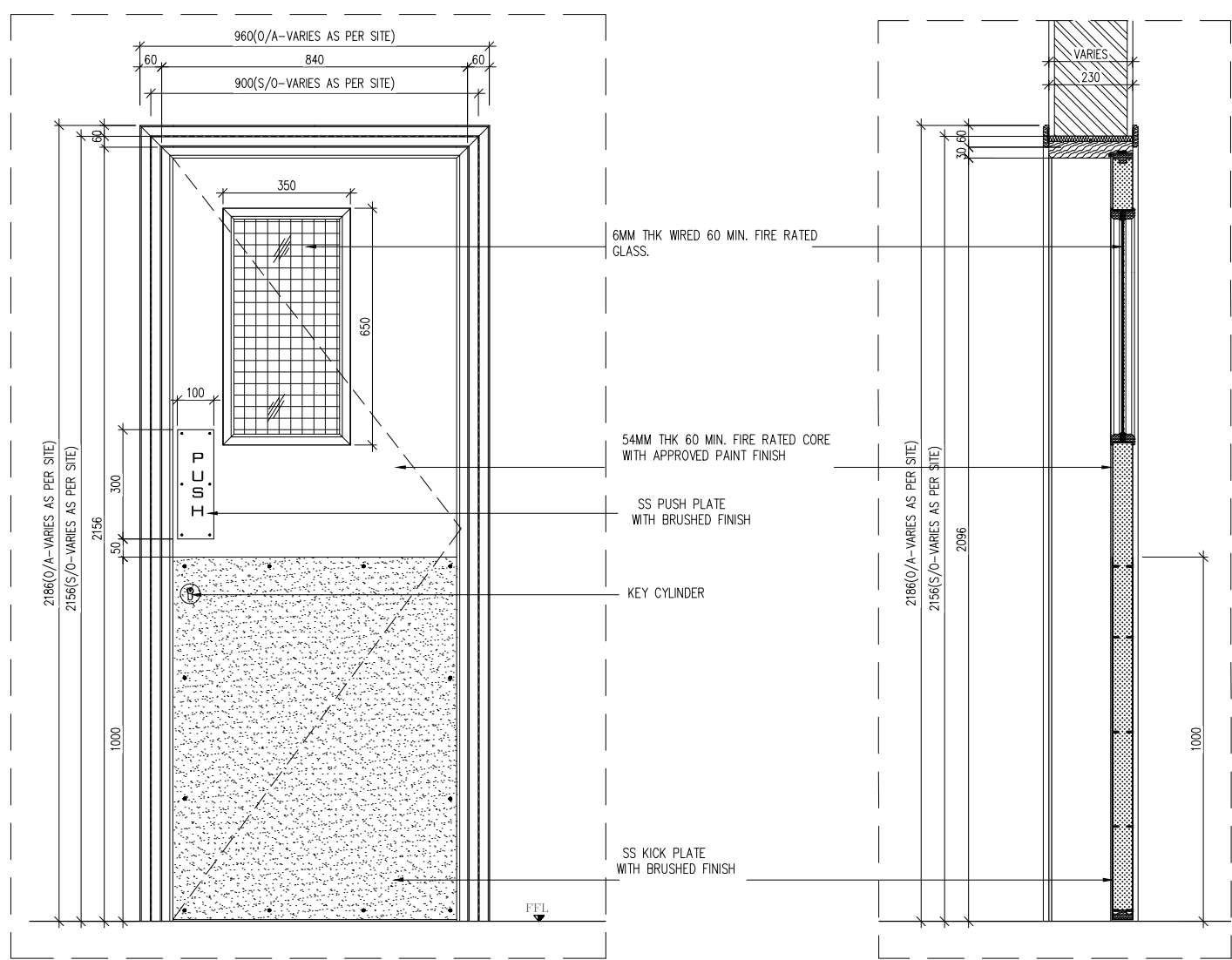
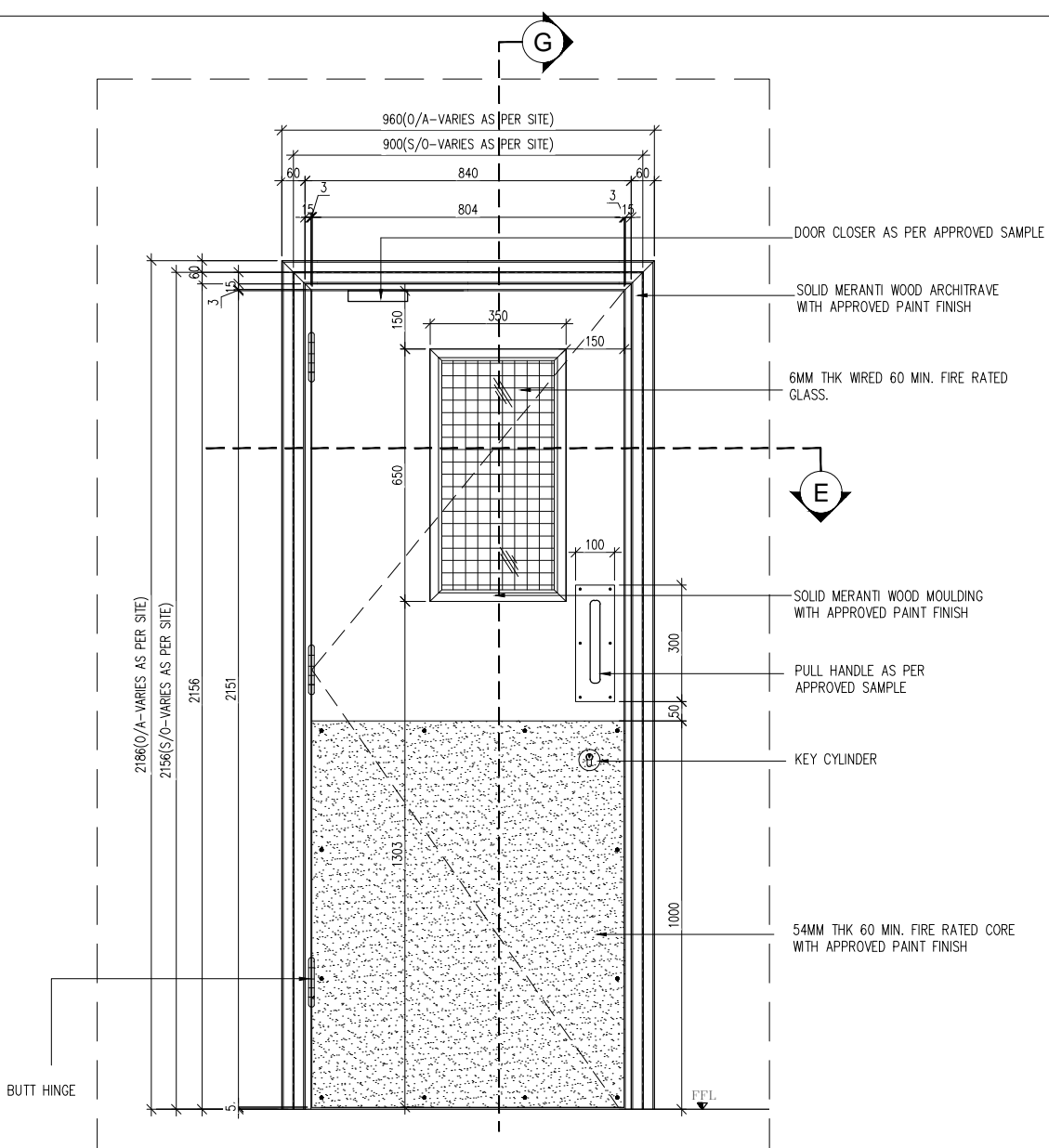

**NOTES:**

COPYRIGHT OF DESIGNS SHOWN HEREIN IS RETAINED BY THIS OFFICE AND AUTHORITY IS REQUIRED FOR ANY REPRODUCTION.

CONTRACTOR TO VERIFY ALL DIMENSIONS ON SITE BEFORE COMMENCING WORK. FIGURED DIMENSIONS GIVEN ARE TO BE TAKEN IN PREFERENCE TO SCALING.

ALL CONSTRUCTION SHALL COMPLY WITH THE CURRENT EDITION OF THE LOCAL BUILDING CODES & REGULATIONS AND ALL OTHER APPLICABLE CODES, ORDINANCES AND STATUTES.

SHOP DRAWINGS SHALL BE PROVIDED AS REQUIRED FOR MILLWORK/ CUSTOM AND METAL INTERIOR ARCHITECTURAL DETAILS.

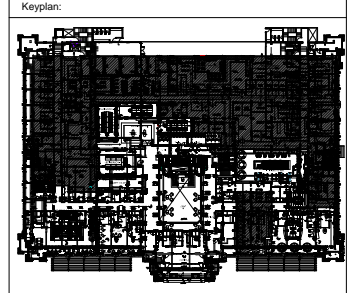

DRAWING IS			
<input type="checkbox"/> A	Approved	<input type="checkbox"/> C	Review and Resubmit
<input type="checkbox"/> B	Approved As Noted	<input type="checkbox"/> D	Revised
<input type="checkbox"/> E	No Action	Signature:	Date: / /
Department	Check	Status	Previous Status
Architectural			
Structural			

Rev.	Date	Description	Rev. by
00	28-06-16	SUBMITTED FOR APPROVE	PASHA

CLIENT :

**WESTWOOD HOTEL**  
P.O. BOX 4423 AJMAN, UAE

PROJECT TITLE :

**Radisson BLU**  
HOTELS & RESORTS  
AJMAN, UNITED ARAB EMIRATES

INTERIOR DESIGN CONSULTANT :

**DESIGN WORK PORTFOLIO**  
Burjuman Business Tower - Level 24  
PO Box 116787, Dubai, United Arab Emirates  
T: +971 4 3519990, F: +971 4 3518858  
E: www.designworkportfolio.com

CONTRACTOR :

**GOLDEN link**  
Contracting & Decoration L.L.C.  
Interior Design Supervision & Contracting  
DUBAI, U.A.E. Tel: 04 388 5425 Fax: 04 388 5426

DRAWING NAME :

**D1- TYPICAL SINGLE SWING DOOR 60 MIN. FIRE RATED WITH VISION PANEL QTY = 2 - NOS.**

Issued for:

**DESIGN DEVELOPMENT**

Scale:	Drawn By:	Check By:	Project No.
@ A3 AS SHOWN	PASHA	MK	RBA
Date	Drawing No.		
18-06-2016	<b>GLK-ARB-FRD-106</b>		<b>00</b>
			Revision



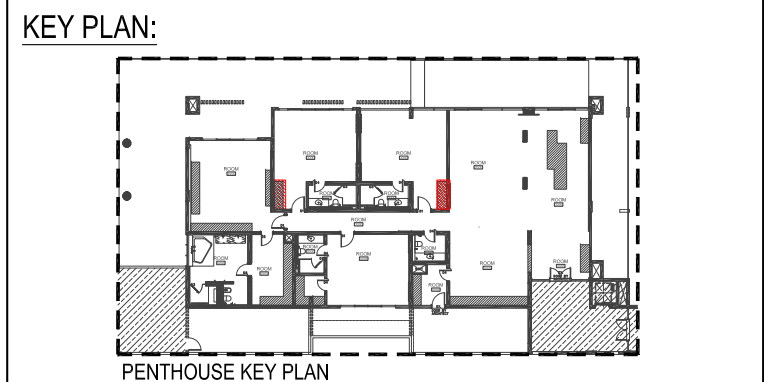
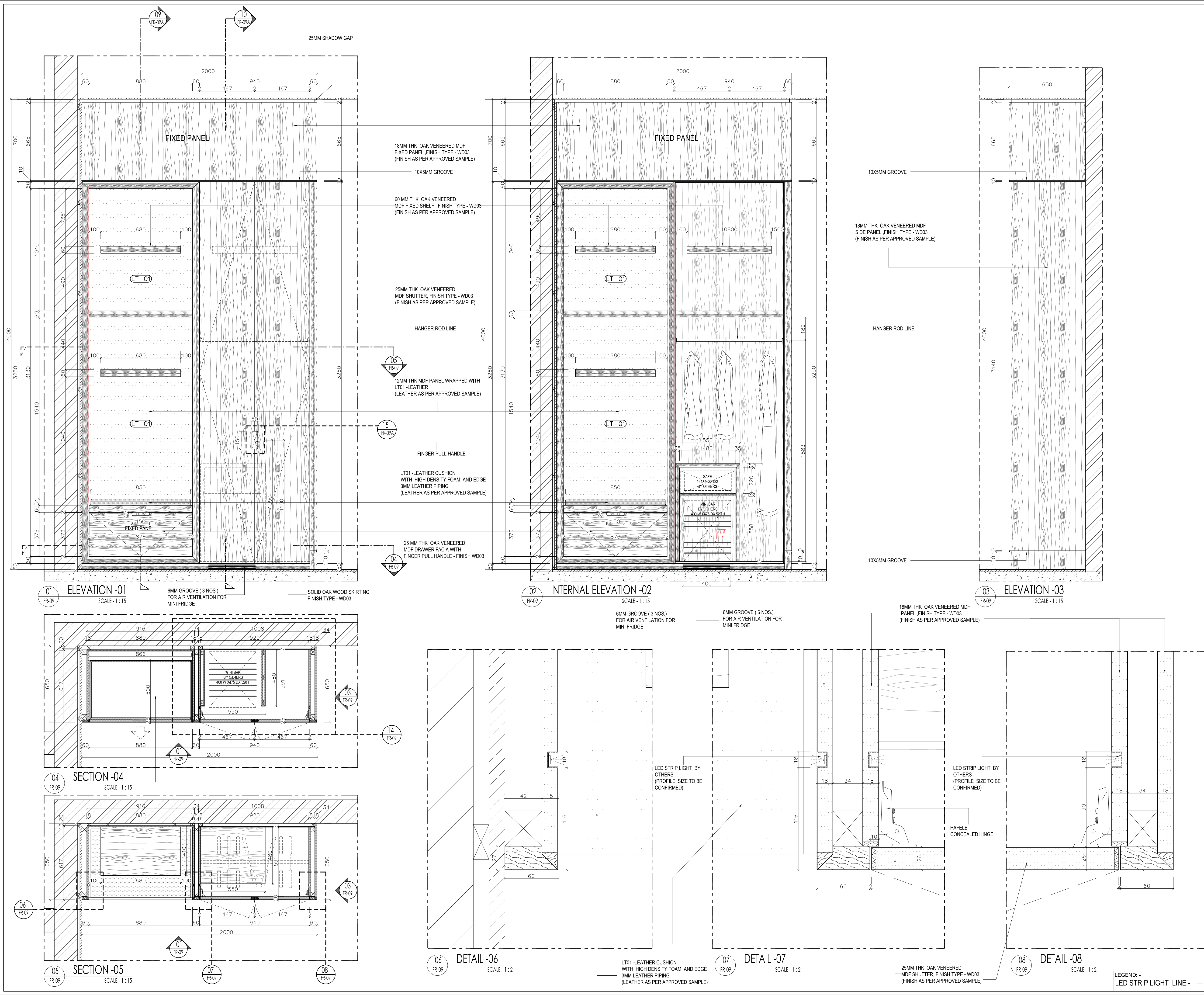

**GENERAL NOTES:**

- \* THIS DRAWING IS THE COPYRIGHT OF GOLDEN LINK INDUSTRIES LLC. AND MUST NOT BE RETAINED, COPIED OR USED WITHOUT GOLDEN LINK INDUSTRIES AUTHORITY.
- \* DO NOT SCALE FROM THIS DRAWING.
- \* ALL DIMENSIONS ARE IN MILLIMETERS UNLESS INDICATED OTHERWISE.
- \* THIS DRAWING SHOULD READ IN CONJUNCTION WITH OTHER RELEVANT DESIGN, STRUCTURAL, MECHANICAL & ELECTRICAL DRAWINGS AND ALL RELEVANT SECTIONS OF THE SPECIFICATIONS.
- \* ALL DIMENSIONS ARE TO BE CHECKED ON SITE PRIOR TO ANY WORKS BEING PUT IN HAND.
- \* ANY DISCREPANCIES IN THE DRAWING ARE TO BE BROUGHT TO THE IMMEDIATE NOTICE OF THE DESIGNER.

DRAWING IS		C Revise and Resubmit	
<input checked="" type="checkbox"/> A Approved	<input type="checkbox"/> B Approved As Noted	<input type="checkbox"/> D Rejected	
<input type="checkbox"/> E No Action	Signature: <b>pathara</b> Date: <b>17/09/01</b>		
Department	Check	Status	Previous Status
Architectural			
Structural			

**REVISIONS:**

REV.	DATE	DESCRIPTION	DRAWN	CHKD.
00	06-06-17	ISSUED FOR APPROVAL	SUDHI	
01	29-08-17	REVISED & ISSUED FOR APPROVAL	SUDHI	

**CLIENT:**

*Fairmont*  
HOTELS & RESORTS  
FAIRMONT HOTEL & RESORTS  
FUJAIRAH, UAE.

**DESIGN CONSULTANT:**

*Kristina Zanic*  
DESIGN CONSULTANTS  
www.kristinazanic.com  
DUBAI, UAE

**CONSULTANT:**

*erga*  
Dubai, tel: 971 4 2480690  
fax: 971 4 2465846  
P.O. box 30509, Dubai, U.A.E.  
إيرغا للتطوير والهندسة - دبي

**MAIN CONTRACTOR:**

سنيار الخليل للمقاولات ذ.م.ج  
SINYAR AL KHALEEJ CONT. L.L.C. *Sinyar*

**SUB CONTRACTOR:**

**GOLDEN link**  
INDUSTRIES LLC  
Kitchen | Wardrobe | Doors | Joinery  
Tel: 07 244 4377, Fax: 07 244 4378 - RAK - UAE  
Tel: 04 388 5425, Fax: 04 388 5426 - Dubai - UAE

**JOB TITLE:**  
FAIRMONT HOTEL & RESORTS  
FUJAIRAH, UAE.  
Project No. K216-35

**SHOP DRAWING**

DWG TITLE:  
PENTHOUSE BED ROOM 2 & 3  
WARDROBE - J09 DETAILS  
QUANTITY - 2 NOS. (1no. L/H & 1no. R/H)  
SHEET - 01

Date	Drawn	Scale	Chkd.	Appd.
27-05-17	SUDHI	AS SHOWN IN A1	-	-
ID Drawing ref. no:	KZ-PEN-4009 - REV 2		Sheet :	Rev. no.
Dwg. no:	GL-SD-FHR-FR-09	1/1		01

LEGEND: -  
LED STRIP LIGHT LINE - - - - -



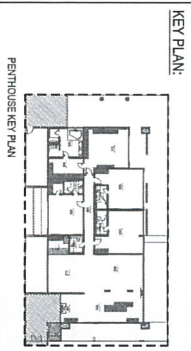
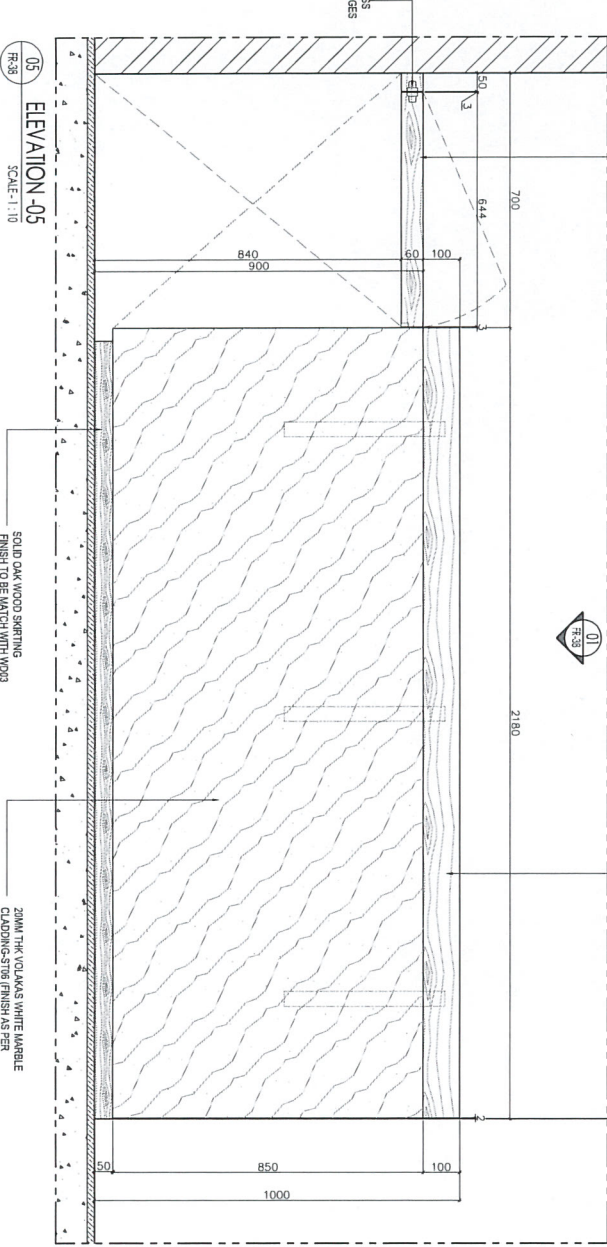
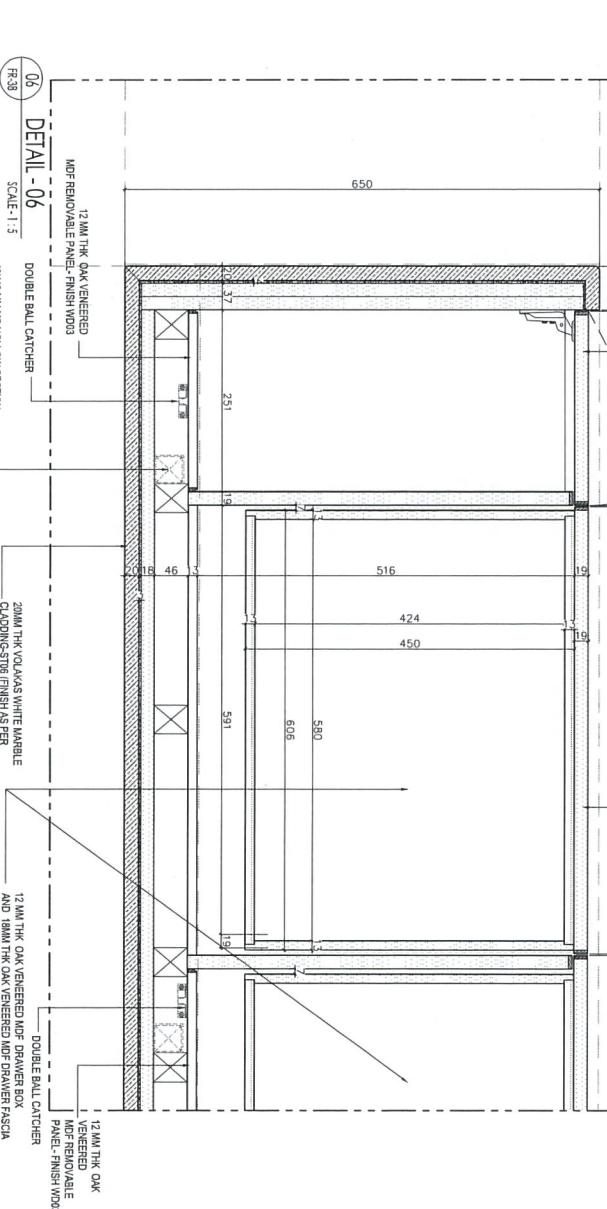
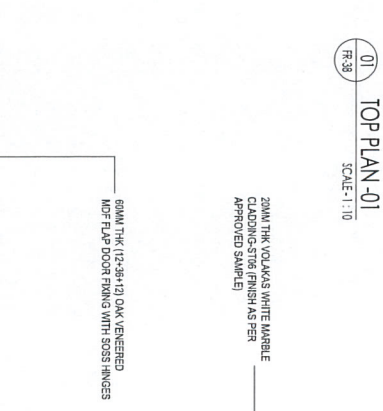
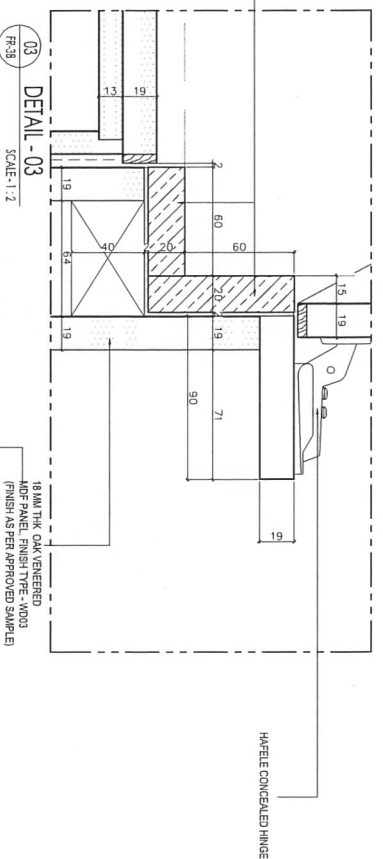
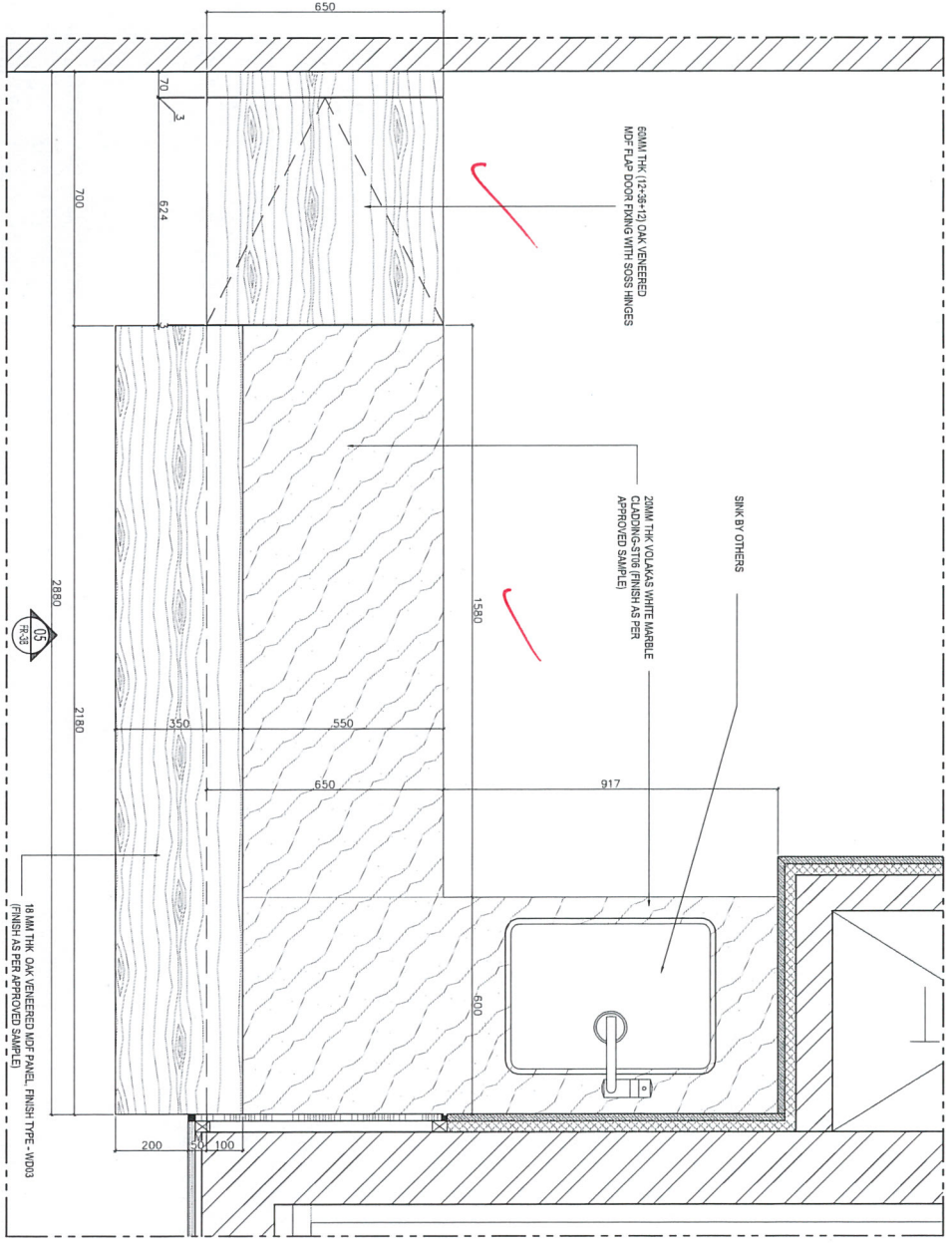
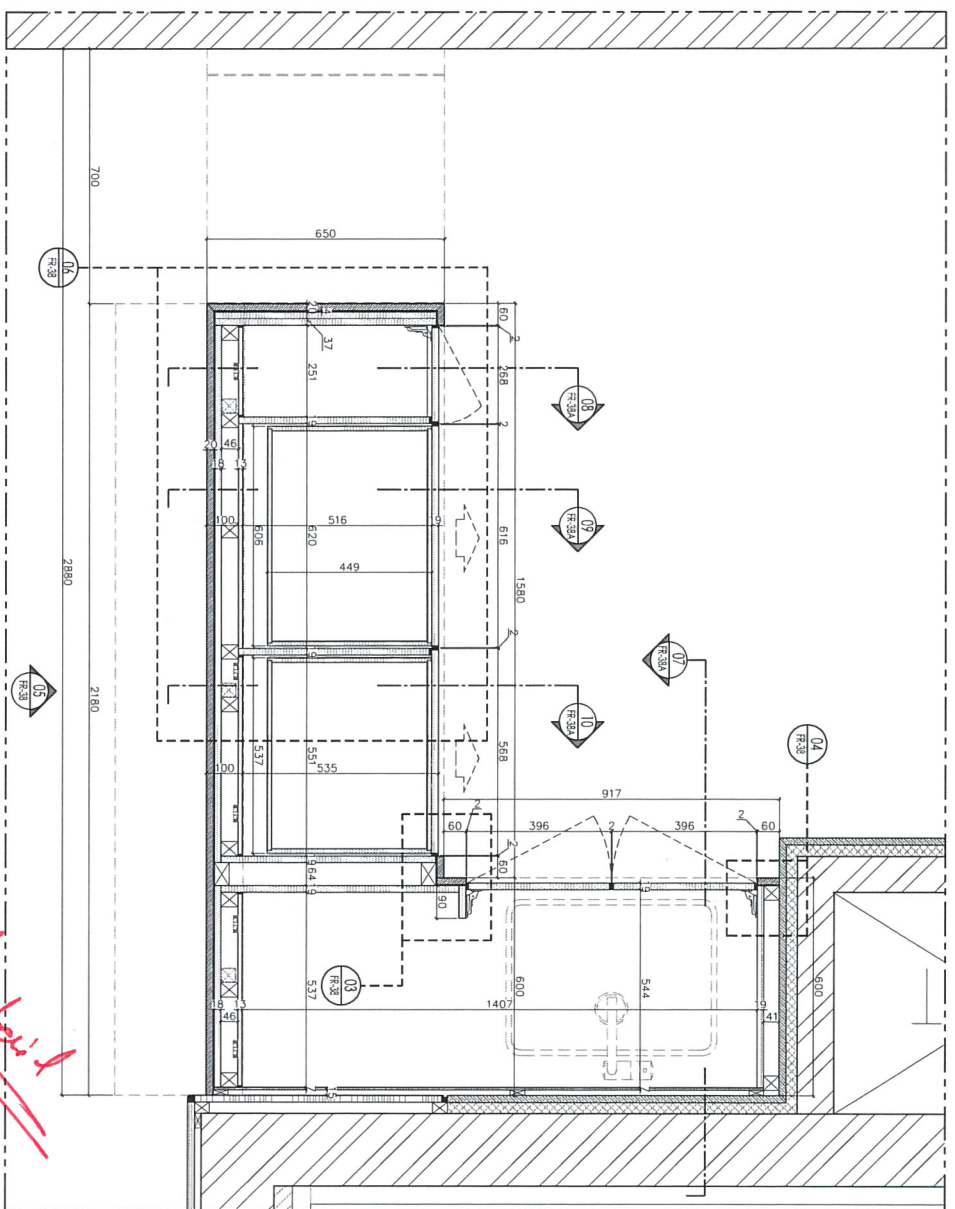

**GENERAL NOTES:**

- THIS DRAWING IS THE COPYRIGHT OF GOLDEN LINK INDUSTRIES LLC AND MUST NOT BE REPRODUCED, COPIED OR USED WITHOUT GOLDEN LINK INDUSTRIES APPROVAL.
- DO NOT SCALE FROM THIS DRAWING.
- ALL DIMENSIONS ARE IN MILLIMETERS UNLESS INDICATED OTHERWISE.
- THIS DRAWING SHOULD BE READ IN CONJUNCTION WITH OTHER ELECTRICAL DRAWINGS AND ALL RELEVANT SECTIONS OF THE SPECIFICATIONS.
- ALL DIMENSIONS ARE TO BE CHECKED ON SITE PRIOR TO ANY WORKS BEING PUT IN HAND.
- ANY DISCREPANCIES IN THE DRAWING ARE TO BE BROUGHT TO THE ENGINEER'S NOTICE ON THE SPOT.

**REVISIONS:**

REV.	DATE	DESCRIPTION	DRAWN	CHECK
01	02-26-17	ISSUED FOR APPROVAL	SUDHI	SUDHI
02	02-16-17	ISSUED FOR APPROVAL	SUDHI	SUDHI

**CLIENT:** Fairmont HOTELS & RESORTS  
**DESIGN CONSULTANT:** Kristina Zavic DESIGN CONSULTANTS  
 DUBAI, UAE

**www.kristinazavic.com**

**CONSULTANT:** Kristina Zavic  
 771 2 2485440  
 Tel: 07 2444372 Fax: 07 244 4373 - UAE - UAE  
 P.O. Box 39097 - Dubai - UAE

**MAIN CONTRACTOR:** Sinyar Al Khaleef Cont. LLC  
 سيار الخليفة للتجارة والبناء  
 Sinyar

**SUB CONTRACTOR:** GOLDEN LINK INDUSTRIES LLC  
 Kitchin | Windows | Doors | Joinery  
 Tel: 04 888 5325 Fax: 04 388 5438 - Dubai - UAE

**JOB TITLE:** FAIRMONT HOTEL & RESORTS  
 FUJARAH, UAE.  
 Project No: KZ16-53

**DWG TITLE:** SHOP DRAWING  
 PENHOUSE ISLAND COUNTER-J13 DETAILS  
 QUANTITY - 1 NO.  
 (SHEET 4/1)

Date	Drawn	Scale	Chkd.	Appd.
03-09-17	SUDHI	AS SHOWN IN A1	-	-
Dwg. no.	KZ-PEN-4013		Sheet:	Rev. no.
	GL-SD-FHR-FR-38		1/2	01



18MM THK OAK VENEERED MDF PANEL, FINISH TYPE: WOOD FINISH AS PER APPROVED SAMPLE

6MM THK (125x412) OAK VENEERED MDF FLAP DOOR FINISH WITH SOLIS FINISH

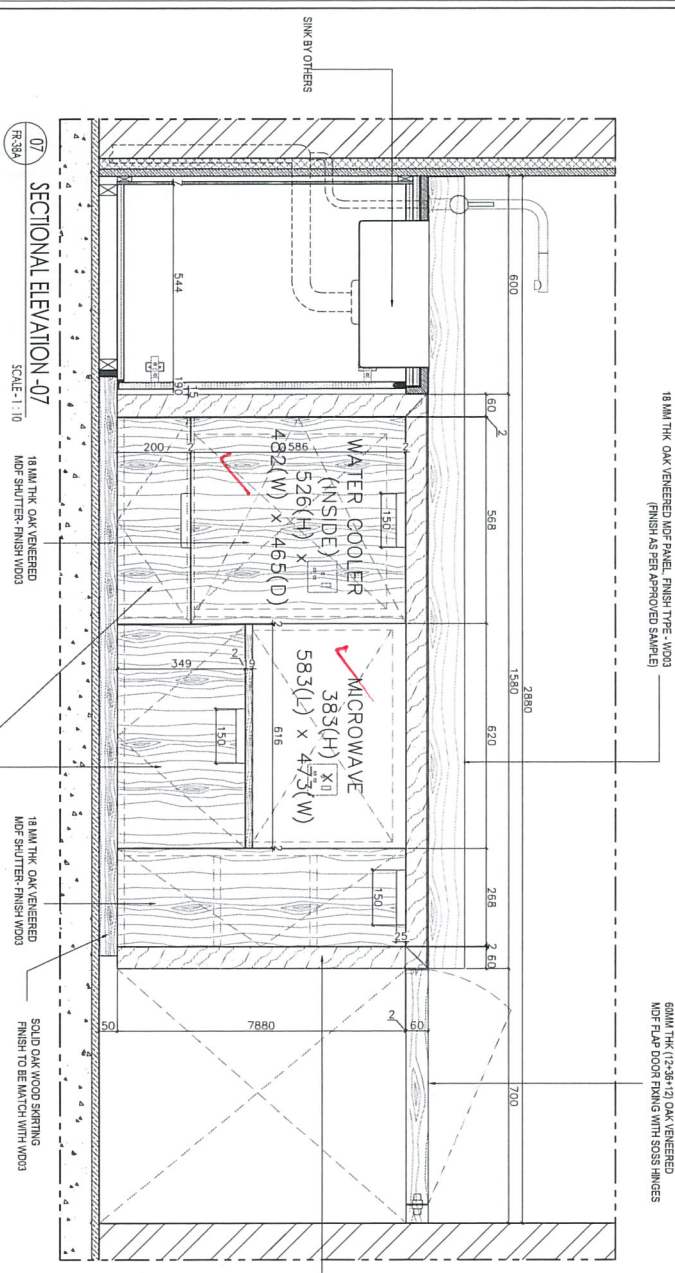

SECTIONAL ELEVATION -07  
SCALE: 1:10

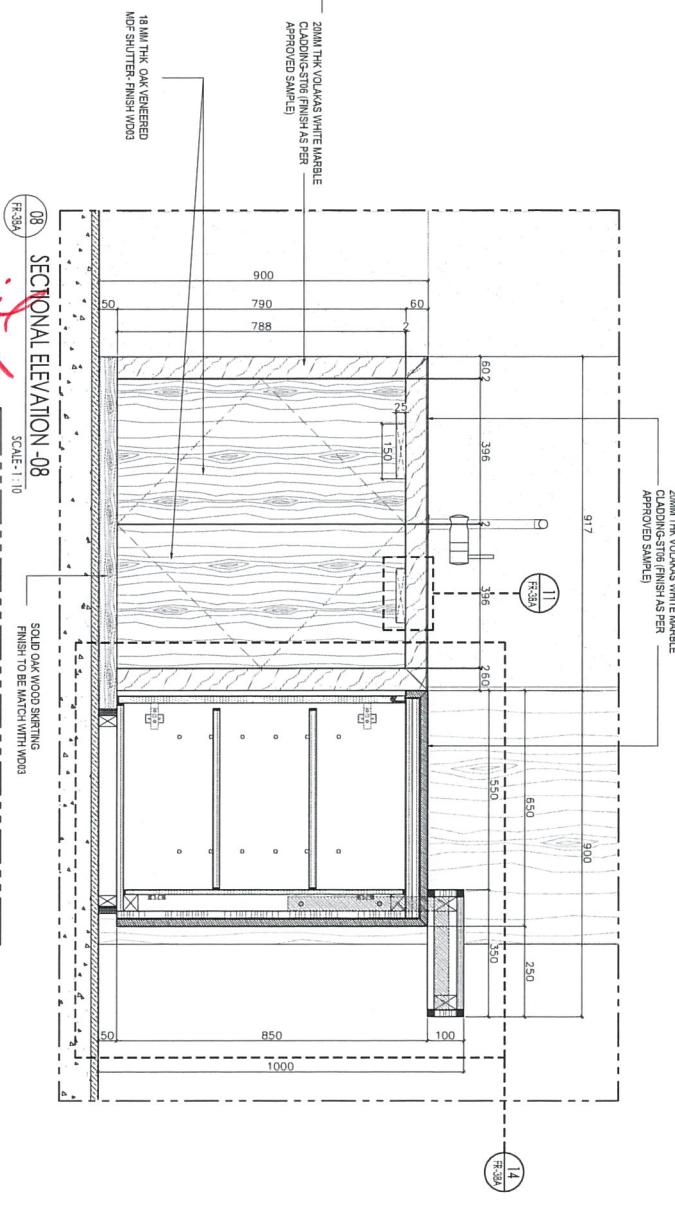

SECTIONAL ELEVATION -08  
SCALE: 1:10

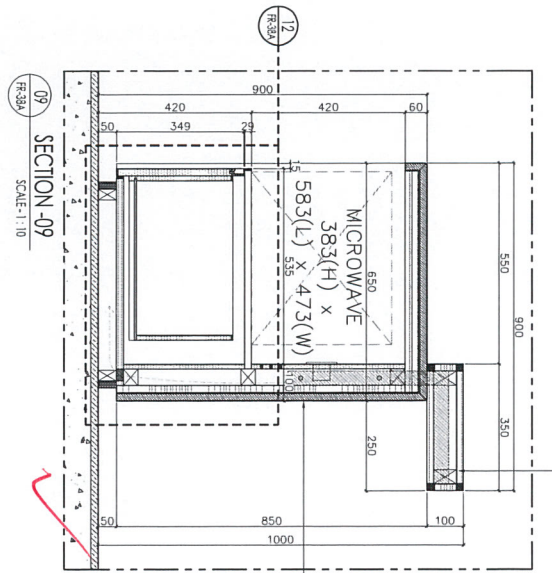

SECTION -09  
SCALE: 1:10

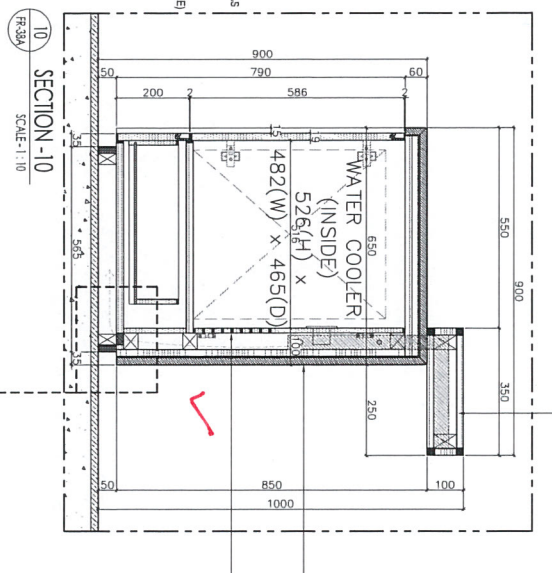

SECTION -10  
SCALE: 1:10

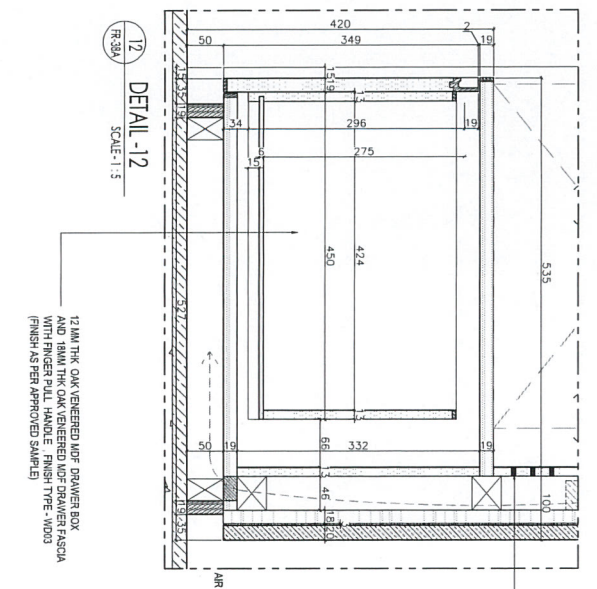

DETAIL -12  
SCALE: 1:5

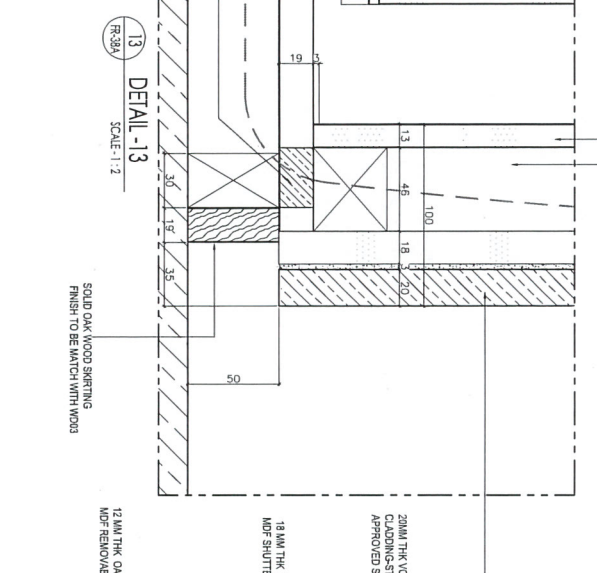

DETAIL -13  
SCALE: 1:2

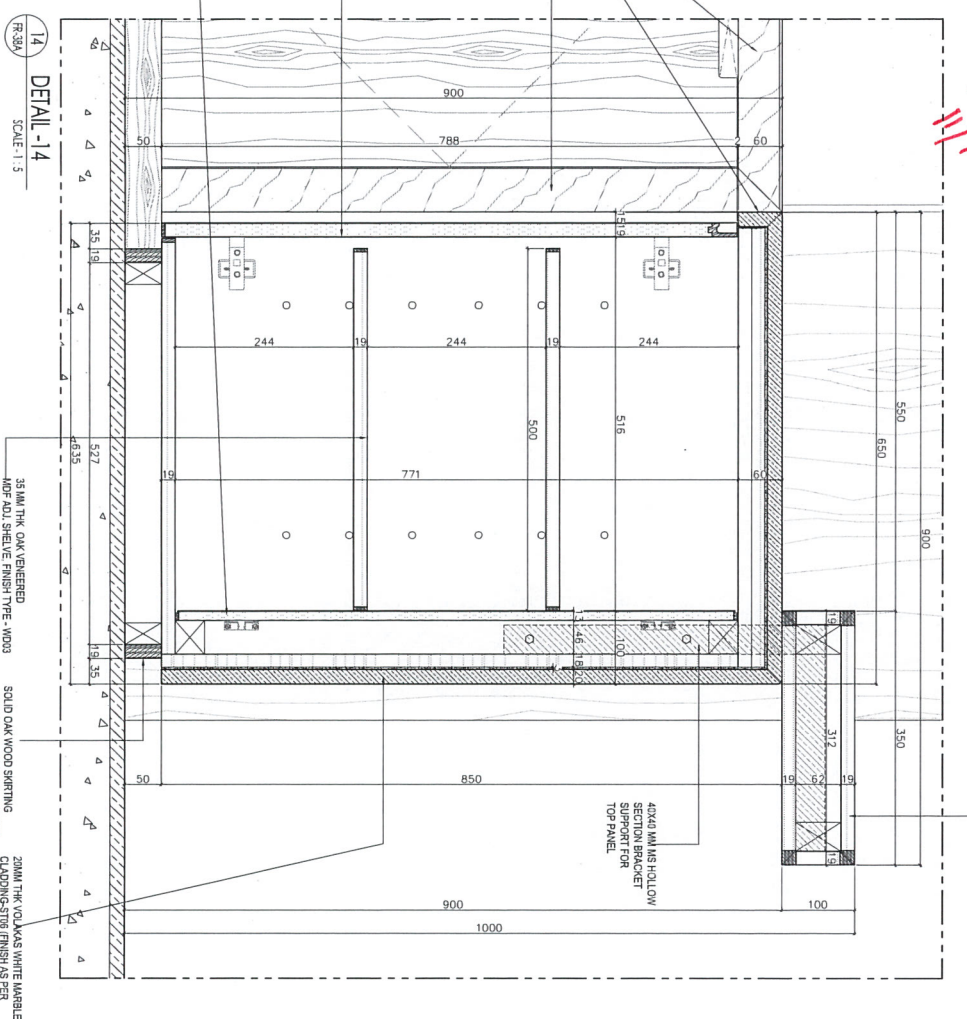

DETAIL -14  
SCALE: 1:5

good/detail  
ok  
Approved  
11/10/17

KEY PLAN:

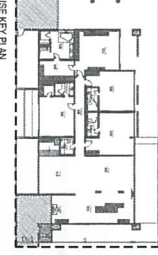

GENERAL NOTES:

- \* THIS DRAWING IS THE COPYRIGHT OF GOLDEN LINK INDUSTRIES LLC AND MUST NOT BE REPRODUCED, COPIED OR USED WITHOUT THE WRITTEN PERMISSION OF GOLDEN LINK INDUSTRIES LLC.
- \* DO NOT SCALE FROM THIS DRAWING.
- \* ALL DIMENSIONS ARE IN MILLIMETERS UNLESS INDICATED OTHERWISE.
- \* THE DRAWING SHOULD BE READ IN CONJUNCTION WITH OTHER RELEVANT DESIGN, STRUCTURAL, MECHANICAL & ELECTRICAL DRAWINGS AND ALL RELEVANT SECTIONS OF THE SPECIFICATIONS.
- \* ALL DIMENSIONS ARE TO BE CHECKED ON SITE PRIOR TO ANY WORKS BEING PUT IN HAND.
- \* ANY DISCREPANCIES IN THE DRAWING ARE TO BE BROUGHT TO THE IMMEDIATE NOTICE OF THE DESIGNER.

DRAWINGS		REVISIONS	
<input type="checkbox"/> A. Approved	<input type="checkbox"/> C. Recheck and Reissue	REV.	DATE
<input type="checkbox"/> B. Approved At Hand	<input type="checkbox"/> D. Recheck	DESCRIPTION	DRAWN
<input type="checkbox"/> E. Not Approved	<input type="checkbox"/> F. Recheck	ISSUED FOR APPROVAL	CHKD.
		ISSUED FOR APPROVAL	DATE

REV.	DATE	DESCRIPTION	DRAWN	CHKD.
01	03-26-17	ISSUED FOR APPROVAL	SIJDIH	SIJDIH
02	07-16-17	ISSUED FOR APPROVAL	SIJDIH	SIJDIH

CLIENT: **Fairmont**  
HOTELS & RESORTS  
FAIRMONT HOTEL & RESORTS  
FUJAIRAH, UAE

DESIGN CONSULTANT: **Kristina Zovic**  
DESIGN CONSULTANTS

CONSULTANT: **alraza**  
Dubai, UAE  
P.O. Box 355097  
Dubai, UAE

MAIN CONTRACTOR: **سنترا العقار والتجارة**  
**SINVAR AL KHALEEF CONT. LLC**  
Singer

SUB CONTRACTOR: **GOLDEN LINK INDUSTRIES LLC**  
Khalifa | Warden | Debn | Jemery  
Tel: 07 244 4377 Fax: 07 244 4378 - RAJ - UAE  
Tel: 04 888 5432 Fax: 04 318 2418 - Dubai - UAE

JOB TITLE: **FAIRMONT HOTEL & RESORTS FUJAIRAH, UAE.**

DWG TITLE: **SHOP DRAWING**  
PENTHOUSE ISLAND COUNTER-113 DETAILS  
QUANTITY: 1 NO.

Date	Drawn	Scale	Chkd.	Appd.
03-26-17	SIJDIH	AS SHOWN IN A1	-	-
ID Drawing ref. no.	KZ-PEN-4013	Sheet:	Rev:	no.
Dwg. no.	GL-SD-FHR-FR-38A		22	01





Date: 18<sup>th</sup> Oct, 2016.

## AGREEMENT FOR FALSE CEILING WORKS

### FIRST PARTY:

M/S H.E HASSAN ABDULLAH AL ADHAB

IHM HAWL ALSHARQ ALAWST BLDG. CONT.

P.O Box 33224, Dubai UAE.

### SECOND PARTY:

SUPER GOLDEN TECHNICAL WORKS L.L.C

P.O BOX 43262, DUBAI, UAE

PROJECT: 2B+G+12 RES. BLDG ON PLOT 241-174 AT AL NAHDA 2,  
DUBAI

### 1. SCOPE OF WORK:

Supply and installation of false ceiling works including all materials and manpower.

### 2. SAFETY SYSTEM:

a. SUPER GOLDEN TECHNICAL WORKS L.L.C will be responsible for the usage of the machine and the workers are to be skilled executing the job.



18/10/2016



عجائب الفن للأعمال الفنية (ش.ذ.م.م)  
ART WONDERS TECHNICAL WORKS (L.L.C)

Date: 06-Oct-2016.

## AGREEMENT FOR GYPSUM BOARD INSTALLATION

### FIRST PARTY:

M/S ART WONDERS TECHNICAL WORKS L.L.C

P.O Box: 33213, Dubai-U.A.E

And

### SECOND PARTY:

M/S SUPER GOLDEN TECHNICAL WORKS L.L.C

P.O BOX.43282, Dubai UAE.

PROJECT: Burj Vista

### 1.SCOPE OF WORK:

Installation of Gypsum Board for both Partition and False Ceiling including jointing and tapping.

### 2.SAFETY SYSTEM:

Super Golden will be responsible for the usage of the Machine and the workers are to be skilled executing the job. Super Golden will comply with the Local safety requirements such as Workmen Compensation Policy as per the U.A.E Labour Law.

### 3.PAYMENT RATE:

S. No.	Description	Quantity
1-	Gypsum Board Celing	M 2
2-	Partition Gypsum Board	M 2
3-	Bulk Head	Linear Meter
4-	Carnish	Linear Meter

TEL: +971 4 443 9567, Fax: +971 4 443 9867. P.O.Box: 92269, Dubai - UAE. E-mail: [artwonders@artwonders.com](mailto:artwonders@artwonders.com)



(Continued Page2)



**GOLDEN** *link*  
CONTRACTING & DECORATION L L C  
INTERIOR DESIGN | SUPERVISION | CONTRACTING



*"Interior Solutions.....from  
Concept to Creation"*

# **GREEN BUILDING, FSC CERTIFICATES**



ISTITUTO DI CERTIFICAZIONE DELLA QUALITÀ

## FSC - CHAIN OF CUSTODY

NUMERO DI CERTIFICATO / CERTIFICATE NUMBER  
**CQ-COC-000001**                      **CQ-CW-000001**

SI DICHIARA CHE L'ORGANIZZAZIONE / WE HEREBY STATE THAT THE ORGANIZATION

**GRUPPO MAURO SAVIOLA SRL**  
IT - 46019 VIADANA (MN) – VIALE LOMBARDIA 29

VEDASI ALLEGATO / SEE ANNEX  
IL PRESENTE CERTIFICATO NON È DA RITENERSI VALIDO SE NON ACCOMPAGNATO DAL RELATIVO ALLEGATO  
THIS CERTIFICATE IS NOT VALID WITHOUT THE RELEVANT ANNEX

È CONFORME A / COMPLIES WITH  
**FSC-STD-40-004 (VERS.2-1)**                      **FSC-STD-40-005 (VERS.2-1)**  
**FSC-STD-40-007 (VERS.2-0)**

### OGGETTO DI CERTIFICAZIONE / SCOPE OF CERTIFICATION

Produzione di "pannello ecologico®" truciolare grezzo ureico, idrofugo, ignifugo di legno riciclato post-consumo al 100%, utilizzato anche per la produzione di pannelli nobilitati.  
Stampa di pannelli sottili hardboard in fibra FSC 100%, nobilitazione di pannelli sottili mdf in fibra FSC controlled wood, produzione di laminati FSC mix (Sistema a Trasferimento e Percentuale).  
*Production of raw, water-resistant and fire-resistant "ecological panel®" 100% post-consumer recycled wood, used also in the production of melamine particleboards. Printing of FSC 100% hardboard thin panels, finishing with melamine faced FSC controlled wood thinner mdf panels and FSC mix laminated particleboards (Transfer and Percentage System).*

L'ELENCO COMPLETO DEI GRUPPI DI PRODOTTO CERTIFICATI È DISPONIBILE SUL DATABASE FSC ([WWW.FSC-INFO.ORG](http://WWW.FSC-INFO.ORG))  
THE FULL LIST OF PRODUCT GROUPS COVERED BY THE CERTIFICATE IS AVAILABLE ON FSC DATABASE ([WWW.FSC-INFO.ORG](http://WWW.FSC-INFO.ORG))  
IL PRESENTE CERTIFICATO È DI PROPRIETÀ DI CERTIQUALITY SRL. IL CERTIFICATO E LE EVENTUALI COPIE DEVONO ESSERE RESTITUITI O ELIMINATI NEI CASI PREVISTI DAL REGOLAMENTO CERTIQUALITY REG FSC 01  
THE CERTIFICATE REMAINS THE PROPRIETY OF CERTIQUALITY SRL. ACCORDING TO CERTIQUALITY RULES REG FSC 01 THE CERTIFICATE AND ALL COPIES SHALL BE RETURNED OR DESTROYED  
IL PRESENTE CERTIFICATO NON COSTITUISCE DI PER SÉ EVIDENZA CHE UN PRODOTTO FORNITO DAL TITOLARE DELLA CERTIFICAZIONE SIA CERTIFICATO FSC. I PRODOTTI VENDUTI O INVIATI DAL TITOLARE DEL CERTIFICATO POSSONO ESSERE CONSIDERATI COMPRESI NELLO SCOPO DEL CERTIFICATO SOLO QUANDO CHIARAMENTE INDICATO SULLE FATTURE E SUI DOCUMENTI DI TRASPORTO IN CONFORMITÀ A QUANTO PREVISTO DA FSC  
THIS CERTIFICATE ITSELF DOES NOT CONSTITUTE EVIDENCE THAT A PARTICULAR PRODUCT SUPPLIED BY CERTIFICATE HOLDER IS FSC CERTIFIED. PRODUCT OFFERED, SHIPPED OR SOLD BY THE CERTIFICATE HOLDER CAN ONLY BE CONSIDERED COVERED BY THE SCOPE OF THIS CERTIFICATE WHEN THE REQUIRED FSC CLAIM IS CLEARLY STATED ON INVOICES AND SHIPPING DOCUMENTS  
LA VALIDITÀ DEL PRESENTE CERTIFICATO DEVE ESSERE VERIFICATA SUL SITO [WWW.FSC-INFO.ORG](http://WWW.FSC-INFO.ORG)  
THE VALIDITY OF THIS CERTIFICATE SHALL BE VERIFIED ON [WWW.FSC-INFO.ORG](http://WWW.FSC-INFO.ORG)

20/10/2004

PRIMA EMISSIONE / FIRST ISSUE

15/01/2015

EMISSIONE CORRENTE / CURRENT ISSUE

01/12/2019

DATA DI SCADENZA / EXPIRY DATE

  
ERNESTO OPPICI - President of CERTIQUALITY S.r.l.



The mark of  
responsible forestry

© 1996 FOREST STEWARDSHIP COUNCIL A.C.





ISTITUTO DI CERTIFICAZIONE DELLA QUALITÀ

# FSC - CHAIN OF CUSTODY

ALLEGATO / ANNEX

NUMERO DI CERTIFICATO / CERTIFICATE NUMBER

CQ-COC-000001 CQ-CW-000001

## GRUPPO MAURO SAVIOLA SRL

IL PRESENTE ALLEGATO NON E' DA RITENERSI VALIDO SE NON ACCOMPAGNATO DAL RELATIVO CERTIFICATO  
THIS ANNEX IS NOT VALID WITHOUT THE RELEVANT CERTIFICATE

**GRUPPO MAURO SAVIOLA SRL**

IT – 46019 VIADANA (MN) - VIALE LOMBARDIA 29

**GRUPPO MAURO SAVIOLA SRL**

IT – 27036 MORTARA (PV) - VIA LEONARDO DA VINCI 8

**GRUPPO MAURO SAVIOLA SRL**

IT – 46030 SUSTINENTE (MN) - VIA DON LUIGI MARTINI 1709

20/10/2004

PRIMA EMISSIONE / FIRST ISSUE

15/01/2015

EMISSIONE CORRENTE / CURRENT ISSUE

01/12/2019

DATA DI SCADENZA / EXPIRY DATE

  
ERNESTO OPPICI - President of CERTIQUALITY S.r.l.



The mark of  
responsible forestry

© 1996 FOREST STEWARDSHIP COUNCIL A.C.



# CERTIFICATE OF REGISTRATION

**QMI-SAI CANADA LIMITED**

This is to certify that

## **Shanghai Sindo Panel Co., Ltd**

Room 1805 Lucky Mansion, No. 660 Shangcheng Road, Shanghai 200120 China

complies with the requirements of

### **Forest Stewardship Council - Chain of Custody Standard**

for the following scope of registration:

**Tracking of wood based material**

**Product groups: Medium density fiberboard, Hardboard, Plywood**

**Claim: FSC 100%**

**System(s) used: Transfer**

**Standard(s) version: FSC-STD-40-004V 2-1 and FSC-STD-50-001 V 1-2**

Certificate No.: CERT-0065828  
FSC Certificate Code: QMI-COC-001559  
File No.: 1635035

Issue Date: November 12, 2012  
Original Certification Date: November 11, 2012  
Current Certification Date: November 11, 2012  
Certificate Expiry Date<sup>(1)</sup>: November 10, 2017  
Issue Number: 1

Chris Joupst  
President  
QMI-SAI Canada Limited

上海臻日贸易有限公司  
SHANGHAI SINDO PANEL CO., LTD.



Accredited  
FSC-ACC-025  
FSC Trademark © 1996  
Forest Stewardship Council: A-C

FSC COC

The validity of this certificate shall be limited to the scope of the certificate and shall not be extended to other products or services. The certificate holder shall ensure that the products supplied by the certificate holder are FSC certified. The certificate holder shall ensure that the products supplied by the certificate holder are FSC certified. The certificate holder shall ensure that the products supplied by the certificate holder are FSC certified.

Registered by:  
QMI-SAI Canada Limited, 200 Centre Street, Suite 200, Toronto, Ontario, M5H 1K1, Canada.  
The certificate holder retains the property of this FSC certificate. All other marks, symbols, or logos are the property of their respective owners.



**CERTIFICATE OF WOOD TREATMENT N° 12045**  
Agreement NIMP-ISPM 15 : BE-99022 HT

CUSTOMER : NOUV.SOC.MIN.PRODUCTS INT. SA  
CHAMPS DE TIGNEE, 1  
B-4671 BARCHON

**CERTIFICATE OF WOOD TREATMENT**

Date : 10/01/17

WE DO CERTIFY HEREWITH THAT << RADERMECKER S.A. >> HAS PROPERLY  
DISINFECTED ACCORDING TO THE RULES AND REGULATIONS :

**CONCERN :** (see other side)

VARIETY OF WOOD : NORTH EUROPEAN WOOD FOR PLANKS (humidity < 20%) +  
HOME SILVER FIR FOR RAFTERS

DESTINATION : (see other side)

TRANSPORTATION :

CERTIFICATE ESTABLISHED IN

ENGLISH

DETAILS OF TREATMENT :

NAME OF TREATMENT :

HEAT TREATMENT

TEMPERATURE :

56 ° C AT THE CORE

DURATION :

30 MINUTES

MARKING :

BE-99022 HT



J. DEPREZ

**RADERMECKER SA**

Rue des Gaillettes, 1 B-4651 BATTICE

Tél. : +32 87 69 29 10

Fax : +32 87 67 99 32

E-mail : [administration@radermecker.be](mailto:administration@radermecker.be)

Website : [www.radermecker.be](http://www.radermecker.be)

R.C. Verviers : 56.109

T.V.A. : BE 429.538.467

CBC : 197-2560832-66

**CERTIFICATE OF WOOD TREATMENT N° 12045**  
Agreement NIMP-ISPM 15 : BE-99022 HT

**CONCERN :**

8 WOODEN BOXES 1035X1250X1280 MM  
ORDER REF. CFR20170042

**DESTINATION :**





TECHNISCH CENTRUM DER HOUTNIJVERHEID  
*Inrichting erkend bij toepassing van de Besluitwet van 30 januari 1947*

CENTRE TECHNIQUE DE L'INDUSTRIE DU BOIS  
*Établissement reconnu par application de l'arrêté loi du 30 janvier 1947*



## PEFC - CoC CERTIFICAT DE CONFORMITÉ

CTIB-TCHN 0334

délivré par le CTIB-TCHN (Centre Technique de l'Industrie du Bois) à la firme

IBV

Route de la Forêt 1  
B 6690 - VIELSALM

conformément au

PEFC ST 2002: 2013 : « Chain of Custody of Forest Based Products – Requirements »  
PEFC ST 2001: 2008 : « PEFC Logo usage rules - requirement » second edition

selon la méthode de gestion

Pourcentage

pour le produit / l'activité

Scierie - Négoce de bois - Exploitation forestière – Production de Pellets

Dans / depuis son siège de

Route de la Forêt 1  
B 6690 - VIELSALM

Le CTIB-TCHN reconnaît qu'il existe un degré de confiance suffisant que le titulaire est à même, sur la base de son autocontrôle, de garantir la conformité de la production.

Ce certificat a été délivré le  
29/09/2005.

Ce certificat est valable jusqu'au  
28/09/2020.

Bruxelles, 25/09/2015

C. De Roock  
General Manager





N°	Société	Adresse					Première Certification
01	IBV	Route de la Forêt	1	B	6690	Vielsalm	29/09/2005
02	IBH	Am Gartzbroich		D	53937	Schleiden	29/09/2005

